



**Badger Meter Europa GmbH**

# **MoniSonic 4700**

Ultrasonic transit time flow meter



# **INSTRUCTION MANUAL**

May 2006

UF\_MoniSonic4700\_Bedienungsanleitung\_0612\_e.doc

# PREFACE

---

We are grateful for your purchase of Badger Meter's ultrasonic flowmeter.

- First read this instruction manual carefully until an adequate understanding is acquired, and then proceed to installation, operation and maintenance of the converter (sensor) of the ultrasonic flowmeter. Wrong handling may cause an accident or injury.
- The specifications of this flowmeter will be changed without prior notice for further product improvement.
- Modification of this flowmeter is strictly prohibited unless a written approval is obtained from the manufacturer. Badger Meter will not bear any responsibility for a trouble caused by such a modification.
- This instruction manual shall be stored by the person who actually uses the flowmeter.
- After reading the manual, be sure to store it at a place easier to access.
- This instruction manual should be delivered to the end user without fail.

## Request

- It is prohibited to transfer part or all of this manual without permission in written format.
- Description in this manual will be changed without prior notice for further improvement.

Issued in February, 2000

## About ultrasonic flowmeter

The ultrasonic flowmeter in combination with the ultrasonic sensor mounted on the external wall of existing piping, is used to convert the amount of flow of a fluid flowing in the piping into a unified current signal and integrated pulse signal.

### Check on type and specifications

The name of type is inscribed on the specification nameplate. Check the specification nameplate to make sure that type and specifications are correct as ordered (The nameplate is attached to the side of the converter, the upper side of the sensor cover (small type, large type) and the side of the frame (for high temperature)).

#### (1) Specification nameplate

	
Ultrasonic Flow Meter	
Type	_____
Output	DC4-20mA
Power Supply	<input type="checkbox"/> AC100-240V 50/60Hz
	<input type="checkbox"/> DC20-30V
Ser. No.	_____ Mfd. _____
M	

Converter

	
Ultrasonic Flow Meter	
Type	FL _____
_____	
No.	_____ T _____ 19 _____

Large type sensor

	
Ultrasonic Flow Meter	
Type.	_____
Ser. No.	T _____
Mfd.	TK773792 _____

Small type sensor

	Type	FLW	Ser. No.	T
	M f d.	199	Badger Meter Europa GmbH	

High temperature sensor

## (2) Code symbols of converter

1	2	3	4	5	6	7	8	9	10	11	Description	
F	L	H					3	-				
			2									Case structure Outdoor type immersion-proof
				C								Data display Japanese/English selection display
					Y							Application 1-path system
					B							Simultaneous 2-path or 2-pipe system
						3						Power supply 100 to 120V AC 50/60Hz
						4						200 to 240V AC 50/60Hz
								Y				Wiring port With waterproof cable glands [G1/2 female screw]
								A				With waterproof cable glands with union [G1/2 female screw] (With cable glands for plica tube [JIS C 8309, No.17])
									0			Added specifications None
									1			With BCD output
										Y		TAG No. None
										T		With tag plate

### (3) Code symbols of sensor

#### Standard type

1	2	3	4	5	6	7	8	9	10	11	digit	Description	
F	L	W					2	Y	Y				
			1	1	0							Type	
			1	2	0							Small type sensor (Note 1)	
			3	2	0							Small type sensor	
			5	0	0							High temperature sensor	
			5	1	0							Large type sensor (Note 1)	
												Large type sensor	
						Y						Added specification	
						A						None	
												Tag nameplate	
									Y			Mounting method	
									2			Standard	
												Z method	

Note 1: For aging pipes, cast iron pipes or pipes with mortar lining that will interrupt the propagation of ultrasonic signals, Model FLW11 or FLW50 is recommended, where applicable.

Note 2: FLY type signal cables should be ordered.

#### Immersed type

1	2	3	4	5	6	7	8	9	10	11	digit	Description	
F	L	W					2						
			1	1	1							Type	
			1	2	1							Small type sensor immersion type (Note 3)	
			5	0	1							Small type sensor immersion type	
			5	1	1							Large type sensor immersion type (Note 3)	
												Large type sensor immersion type	
						Y						Added specification	
						A						None	
												Tag nameplate	
								B	Y			Exclusive cable	
								C	Y			10 m	
								D	Y			20 m	
								E	Y			30 m	
								F	Y			40 m	
								G	Y			50 m	
								H	Y			60 m	
								I	Y			70 m	
								J	Y			80 m	
								K	Y			90 m	
								L	Y			100 m	
								M	Y			110 m	
								N	Y			120 m	
								P	Y			130 m	
								Q	Y			140 m	
								R	Y			150 m	
									Y			Mounting method	
									2			Standard	
												Z method	

Note 3: For aging pipes, cast iron pipes or pipes with mortar lining that will interrupt the propagation of ultrasonic signals, Model FLW11 or FLW50 is recommended, where applicable.

**(4) Code symbols of signal cable**



1	2	3	4	5	6	7	8	digit	Description
F	L	Y					1		Application sensor (4th digit)
			1						Small and large type sensors
			2						High temperature sensor
									Cable length (5th, 6th, 7th digit)
				0	0	5			5 m
				0	1	0			10 m
				0	1	5			15 m
				0	2	0			20 m
				0	2	5			25 m
				0	3	0			30 m
				0	3	5			35 m
				0	4	0			40 m
				0	4	5			45 m
				0	5	0			50 m
				0	5	5			55 m
				0	6	0			60 m
				0	6	5			65 m
				0	7	0			70 m
				0	7	5			75 m
				0	8	0			80 m
				0	8	5			85 m
				0	9	0			90 m
				0	9	5			95 m
				1	0	0			100 m
				1	1	0			110 m
				1	2	0			120 m
				1	3	0			130 m
				1	4	0			140 m
				1	5	0			150 m



Note) For sensors other than the immersed type, specify the type.

# CAUTION ON SAFETY

**First of all, read this “Caution on safety” carefully, and then use the flowmeter in the correct way.**

- The cautionary descriptions listed here contain important information about safety, so they should always be observed. Those safety precautions are ranked 2 levels; DANGER and CAUTION.

 <b>DANGER</b>	<p>Wrong handling may cause a dangerous situation, in which there is a risk of death or heavy injury.</p>
 <b>CAUTION</b>	<p>Wrong handling may invite a dangerous situation, in which there is a possibility of medium-level trouble or slight injury or only physical damage is predictable.</p>

<p align="center"><b>Caution on installation and wiring</b></p>	
 <b>DANGER</b>	<ul style="list-style-type: none"> <li>• This unit is not explosion-proof type. Do not use it in a place with explosive gases to prevent explosion, fire or other serious accidents.</li> </ul>
 <b>CAUTION</b>	<ul style="list-style-type: none"> <li>• The flowmeter should be installed in a place that meets the operating conditions shown in this instruction manual. Installation at an unsuited place may cause electric shock, fire or incorrect operation.</li> <li>• Install the flowmeter according to the instruction manual. Improper installation may lead to the cause of fall, trouble or incorrect operation.</li> <li>• When installing, make sure that the flowmeter interior is free from cable chips and other foreign objects to prevent fire, trouble, or incorrect operation.</li> <li>• Connect a power source of correct rating to prevent fire accidents.</li> <li>• Before making wiring work, be sure to turn OFF the power supply to prevent electric shocks.</li> <li>• Use wiring materials of correct rating to prevent fire accidents.</li> </ul>

# CONTENTS

---

PREFACE .....	i
CAUTION ON SAFETY .....	vi
CONTENTS .....	vii
1. OPERATING PARTS AND THEIR FUNCTIONS .....	1-1
2. MOUNTING OF CONVERTER .....	2-1
2.1 Selection of mounting place .....	2-1
2.2 Mounting method .....	2-1
2.3 Outline diagram .....	2-2
3. WIRING OF THE CONVERTER .....	3-1
3.1 Before wiring .....	3-1
3.2 Wiring .....	3-1
3.3 Treatment of the wiring port .....	3-1
3.4 Wiring to terminals .....	3-3
3.5 BCD output pin allocation and cable color .....	3-4
4. OPERATION AND WORKS .....	4-1
4.1 Before operation .....	4-1
4.2 Power ON and status .....	4-2
5. SETTING OF PARAMETERS .....	5-1
5.1 Outline of operating procedures .....	5-2
5.2 Description of key operation .....	5-2
5.3 List of setting items .....	5-4
5.4 Setting of parameters .....	5-5
5.4 (1) Setting of piping specifications .....	5-5
5.4 (2) Setting of range .....	5-8
5.4 (3) Setting of damping .....	5-13
5.4 (4) Zero adjustment .....	5-14
5.4 (5) Setting of measurement display specifications .....	5-15
5.4 (6) Low flow output cut .....	5-17
5.4 (7) Setting of integrated output unit and constant .....	5-18
5.4 (8) Setting of measured value high and low limit switch .....	5-22
5.4 (9) Setting of status output .....	5-24
5.4 (10) Calibration of measured value .....	5-26
5.4 (11) Selection of language (English/Japanese) .....	5-27
5.4 (12) Analog output check .....	5-28
5.4 (13) Status output check .....	5-30
5.4 (14) Setting of BCD interface .....	5-31
5.4 (15) Setting of measurement mode .....	5-33



---

5.4 (16)	Designation of analog output destination .....	5-34
5.4 (17)	Setting of serial communication .....	5-35
6.	MAINTENANCE AND INSPECTION .....	6-1
6.1	Maintenance .....	6-1
6.2	Inspection .....	6-1
7.	TROUBLESHOOTING .....	7-1
7.1	How to confirm normal operation .....	7-1
7.1 (1)	LCD indication during measurement .....	7-1
7.1 (2)	Contents displayed on LCD .....	7-1
7.1 (3)	Check of information on measuring conditions .....	7-2
7.1 (4)	LCD indication when power turned ON .....	7-3
7.2	Faults and remedies .....	7-4
7.2 (1)	LCD display abnormal .....	7-4
7.2 (2)	Key abnormal .....	7-4
7.2 (3)	Measured value abnormal .....	7-5
7.2 (4)	Analog output abnormal .....	7-8
7.2 (5)	Remedy for hardware fault .....	7-8
8.	MOUNTING METHOD .....	8-1
8.1	Mounting of sensor .....	8-1
8.1 (1)	Mounting procedure of sensor .....	8-1
8.1 (2)	Selection of mounting place .....	8-2
8.1 (3)	Selection of mounting method .....	8-3
8.1 (4)	Processing of sensor mounting surface .....	8-3
8.1 (5)	Determination of mounting position (with Z method for large and small types) .....	8-4
8.1 (6)	Cable end treatment .....	8-5
8.1 (7)	Connection of cable to small type sensor .....	8-6
8.1 (8)	Mounting of small type sensor on pipe .....	8-7
8.1 (9)	Assembling procedure of the sensor .....	8-9
8.1 (10)	Connection of cable to large type sensor .....	8-10
8.1 (11)	Mounting of large type sensor on pipe .....	8-11
8.1 (12)	Mounting of high temperature sensor on pipe .....	8-12
	APPENDIX 1. HOW TO MAKE GAUGE PAPER .....	A-1
	APPENDIX 2. COMPOSITION OF KEY OPERATION .....	B-1
	APPENDIX 3. EXTERNAL COMMUNICATION SPECIFICATIONS .....	C-1
	APPENDIX 4. PIPING DATA .....	D-1

# 1. OPERATING PARTS AND THEIR FUNCTIONS

The names and functions of parts of the converter are as follows.

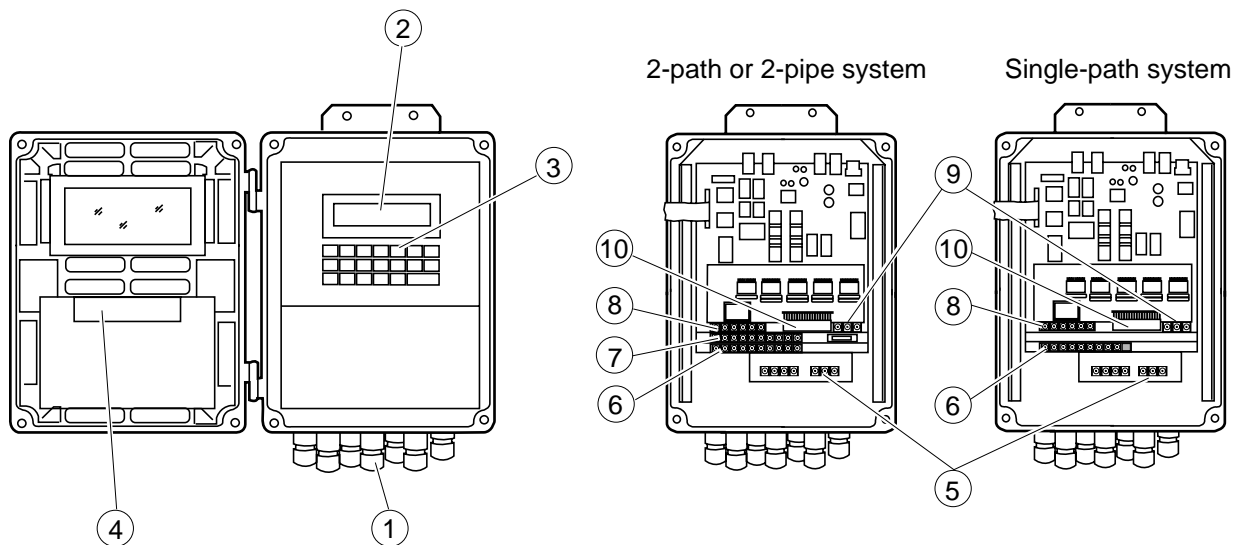

Names of parts of converter

Item	Description
① Wiring port	Wiring port for power cable and signal cable
② Data indicator	Liquid crystal indicator for measurement data and set values
③ Key board	Used for setting the conditions of adjustments and measurements.
④ Parameter table	Used for entering setting data.
⑤ Power terminal block	Used for connecting power cable.
⑥ Measuring unit terminal block (single-path system)	} Used for connecting signal cables from sensor.
⑦ Measuring unit terminal block (2-path system)	
⑧ Controller unit terminal block	Used for connecting signal cables for analog output and status output.
⑨ Terminal block for external communication	Serial interface terminals
⑩ BCD connector	BCD output interface connectors

## 2. MOUNTING OF CONVERTER

### 2.1 Selection of mounting place

Install the converter at a place satisfying the following conditions.

- ① Ambient temperature does not exceed a range of  $-10^{\circ}\text{C}$  to  $+50^{\circ}\text{C}$ . When installing outdoors, attach a shade or put the converter in an outdoor panel to protect it from direct sunlight.
- ② Not exposed to moisture. Even an immersion-proof type is not protected against entry of water. Make arrangements so that water can be drained quickly.
- ③ Not exposed to dust or corrosive gases.
- ④ Free from vibrations and shocks.
- ⑤ Space shown in Fig.2-1 is available for easy inspection and adjustment.

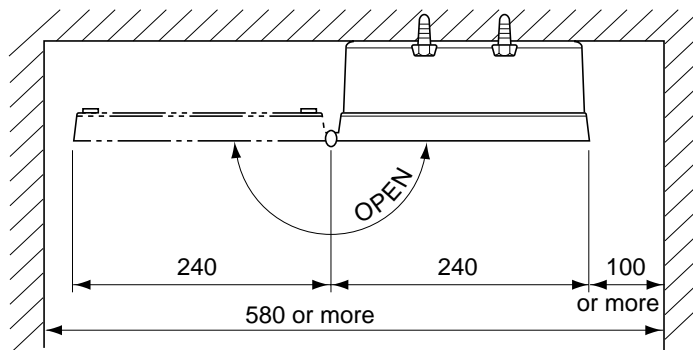

Fig. 2-1 Installation space (top view)

### 2.2 Mounting method

Wall mounting or 2B bypass stand mounting is available for the converter.

For wall mounting, use M10 bolt  $\times$  4 pc.

Be sure to mount the converter at correct position as shown in Fig. 2-2.

Make a hole in the wall or the like according to the cutout dimensions shown in the diagram below, and mount the converter with M10 bolts.

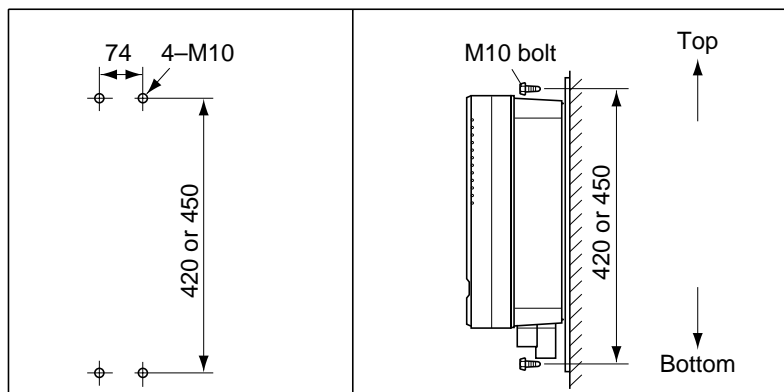
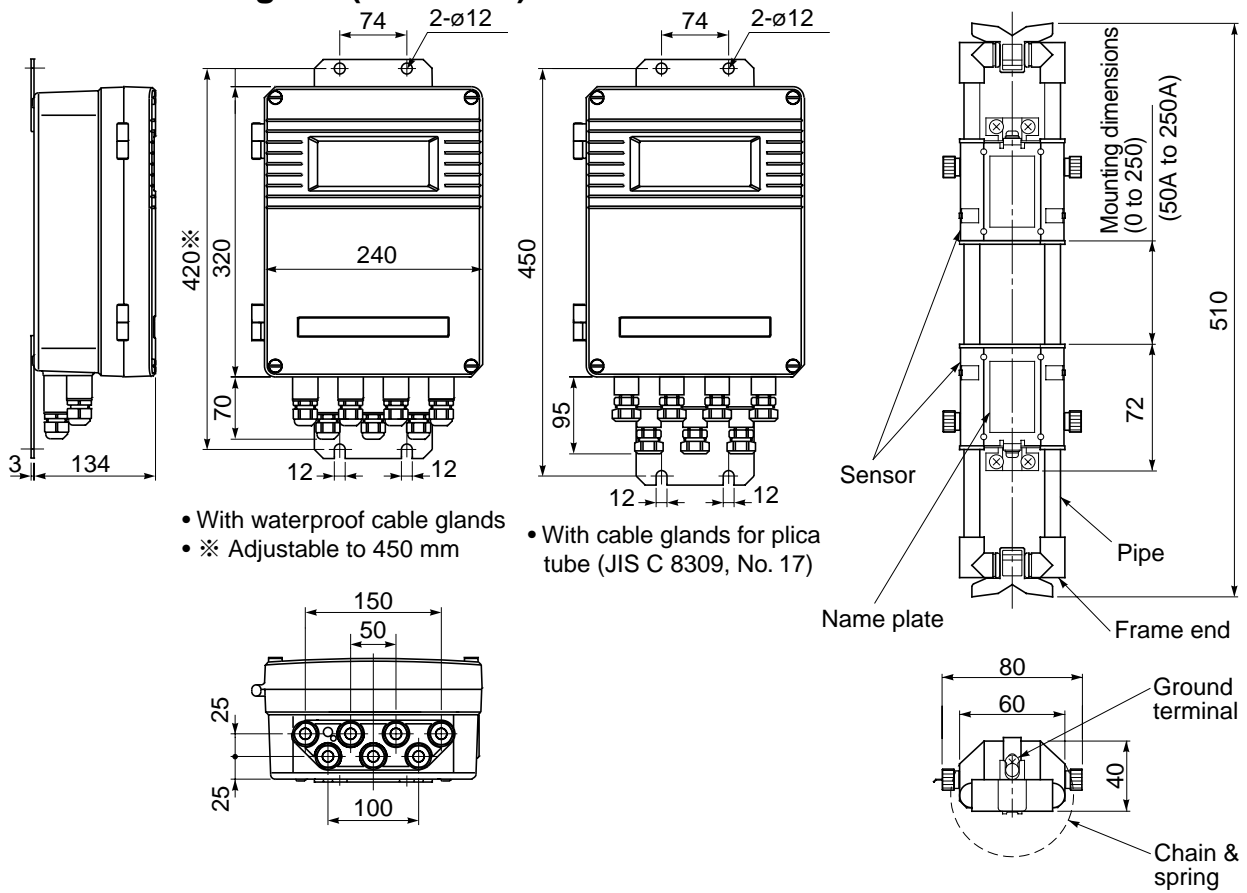

Fig. 2-2 Mounting method

In case of 2B pipe standing type, use U bolts (M8) on the market.

### 2.3 Outline diagram (unit : mm)



**Converter FLH-3**

**Sensor FLW1 (small type sensor)**

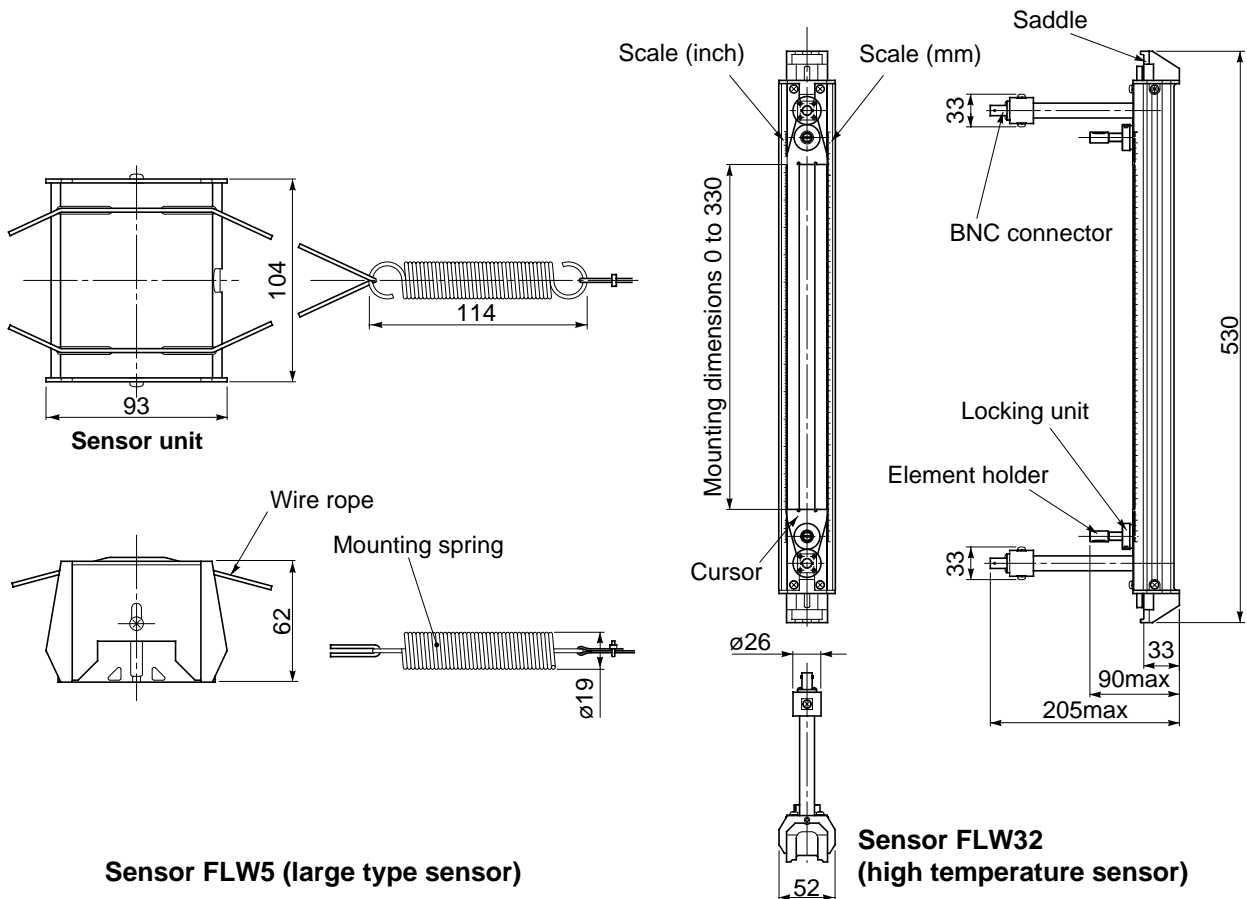

**Sensor FLW5 (large type sensor)**

**Sensor FLW32 (high temperature sensor)**

## 3. WIRING OF THE CONVERTER

---

### 3.1 Before wiring

- ① For signal cable between the sensor and converter, use double-shielded coaxial cables specified by Badger Meter.
- ② The signal cable between the sensor and converter should be run in metallic conduits. To prevent the effects of induction noise, upstream and downstream signal cables should be wired as far away from power cable as possible.
- ③ An output signal cable should use shielded cable as much as possible.
- ④ To prevent the effects of noise, do not install signal cables together with power cable in the same duct.
- ⑤ A power cable is provided with earth wire, it should be connected to the ground.
- ⑥ As this instrument is not equipped with a power switch, be sure to mount a power switch on the instrument.
- ⑦ Wiring ports should be closed when they are not ready to use.

### 3.2 Wiring

Use the following cables :

- Power cable : 3 or 2 core cabtyre cable,  
Nominal sectional area : 0.75mm<sup>2</sup> or more,  
Finished outside diameter :  $\phi$ 11mm
- Output signal cable : 2 core cable or multi-core cabtyre cable as needed.  
Finished outside diameter :  $\phi$ 11mm
- Cable between sensor and converter :  
Signal cable specified by Code Symbols  
(High frequency coaxial cable with characteristic impedance of 50 $\Omega$ )  
Finished outside diameter :  $\phi$ 7.3mm
- BCD cable : 40-core cable  
Finished outside diameter :  $\phi$ 11

### 3.3 Treatment of the wiring port

The converter is an immersion-proof type specified by JIS C0920 "Rules for water-proof tests of electromechanical instruments and wiring materials". However, if the converter is to be installed in a pit, air tightness treatment should be provided for the wiring port to prevent possible entry of moisture, dew condensation or immersion of water.

Waterproof measures should be taken by using waterproof gland or plica tube gland furnished with this instrument. A gland, which is not ready to be used, should be sealed by supplied cover.

< Configuration Diagram >

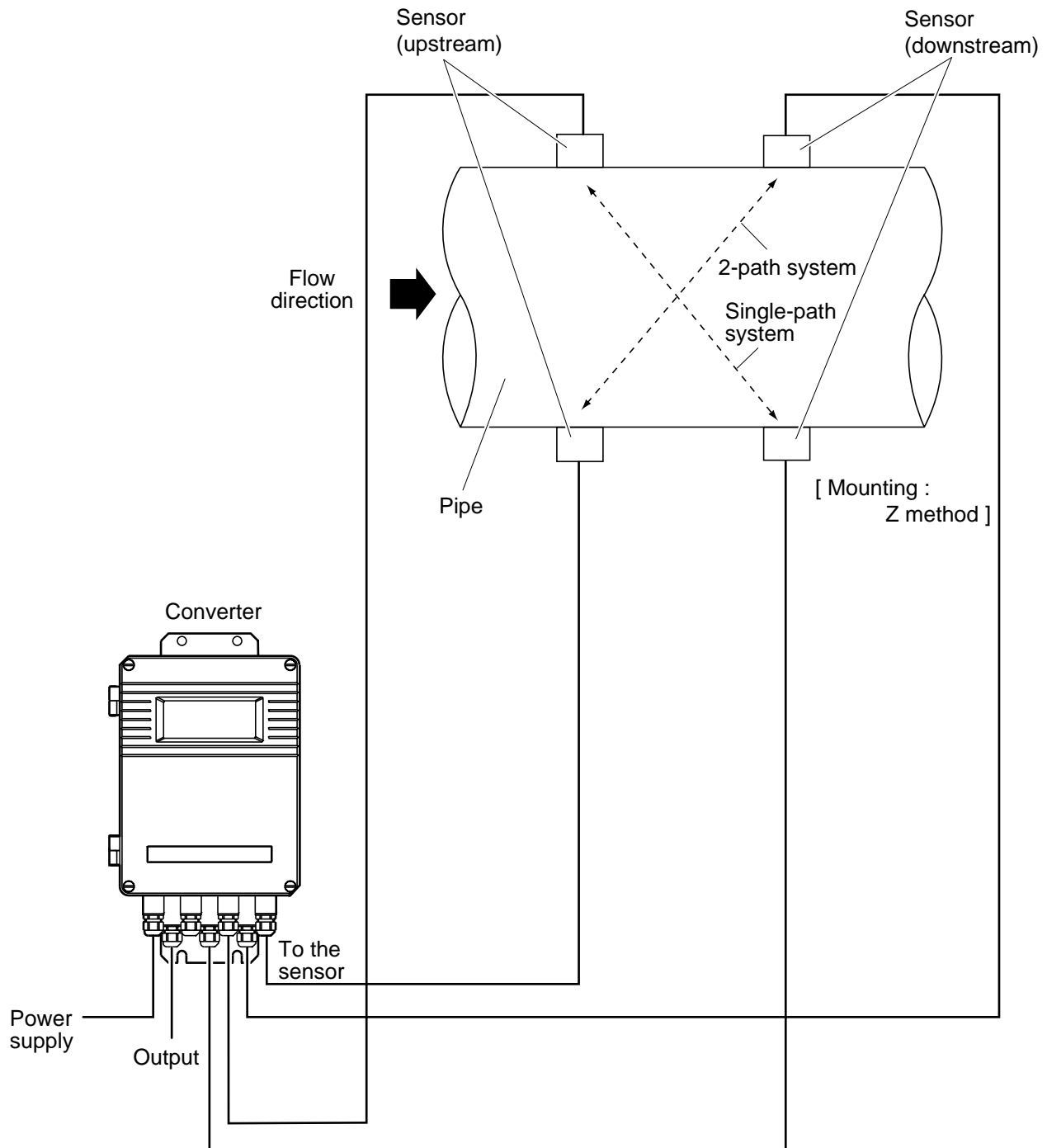

### 3.4 Wiring to terminals

Cables should be connected as shown in the following diagrams.

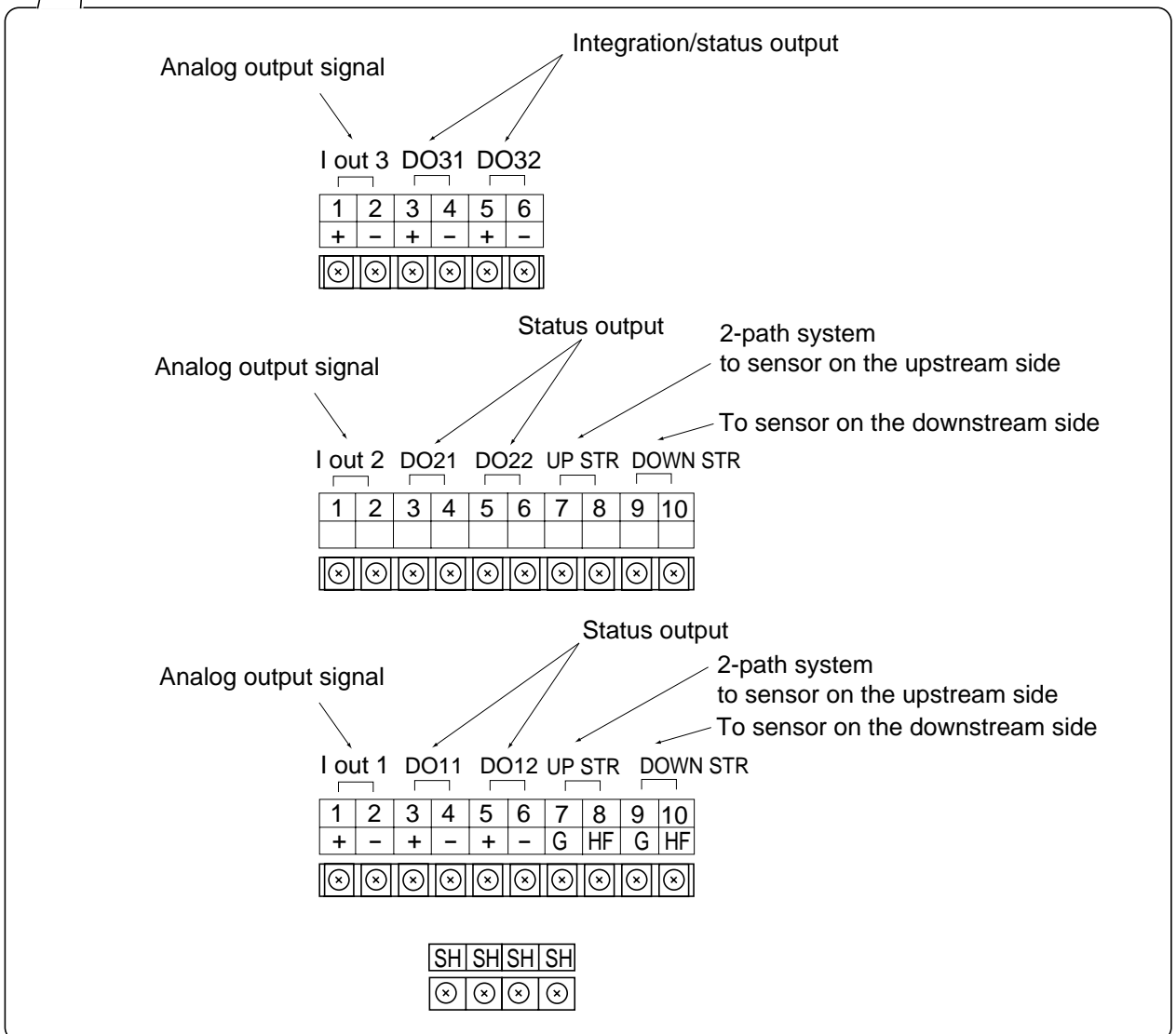
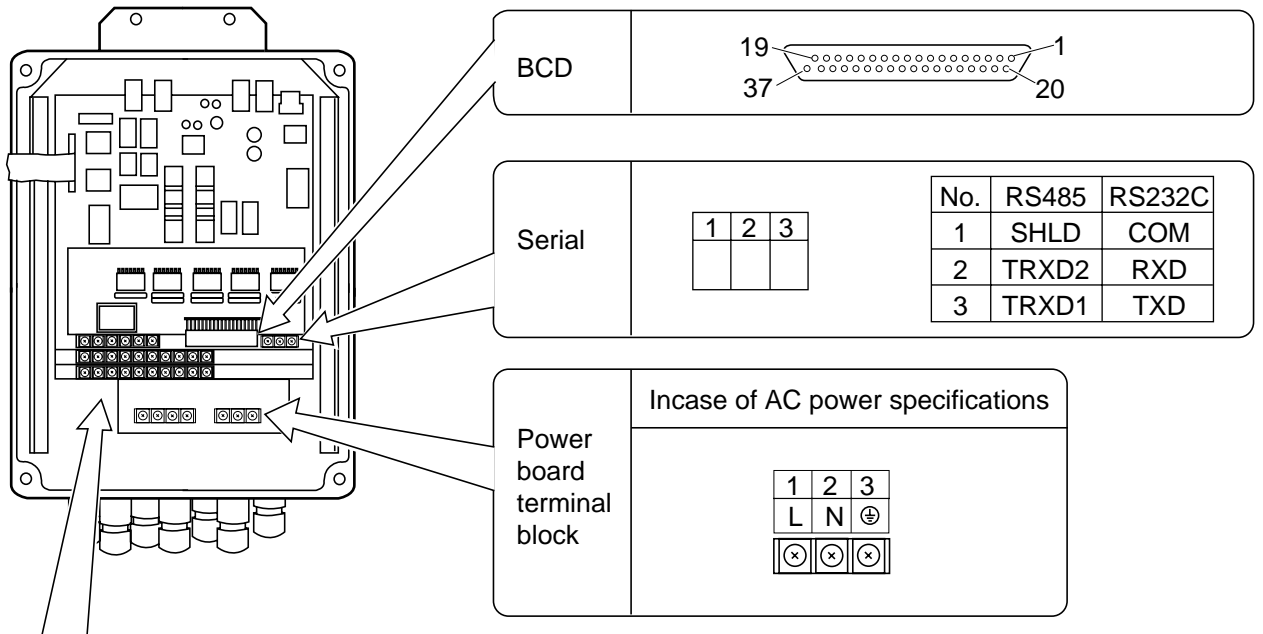

### 3.5 BCD output pin allocation and cable color

Contents	Pin NO.	Cable		
		Color	Indentification	
10 <sup>0</sup>	1	20	Red	–
	2	2	Red	White
	4	21	Green	–
	8	3	Green	White
	P	32	Yellow	–
10 <sup>1</sup>	1	22	Yellow	White
	2	4	Blown	–
	4	23	Blown	White
	8	5	Blue	–
	P	14	Blue	White
10 <sup>2</sup>	1	24	Gray	–
	2	6	Gray	White
	4	25	Orange	–
	8	7	Orange	White
	P	33	Purple	–
10 <sup>3</sup>	1	26	Purple	White
	2	8	Yellowish green	–
	4	27	Yellowish green	White
	8	9	Pink	–
	P	15	Pink	White

Contents	Pin NO.	Cable		
		Color	Indentification	
10 <sup>4</sup>	1	28	Sky blue	White
	2	10	White	–
	4	29	White	Black
	8	11	Green	Black
	P	34	Green	Red
10 <sup>5</sup>	1	30	Yellow	Black
	2	12	Yellow	Red
	4	31	Blown	Black
	8	13	Blown	Red
	P	16	Blue	Black
GND	1	Black	–	
GND	36	Black	White	
BUSY	19	Sky blue	–	
Reserved	37	Orange	Red	
Reserved	18	Orange	Black	
Reserved	35	Gray	Red	
Reserved	17	Gray	Black	



## 4. OPERATION AND WORKS

---

### 4.1 Before operation

Check the following before starting operation.

#### 1. Power

Power check ..... See Item 4.2 (1)

#### 2. Wiring

① Check of main board terminal block .....  
② Check of power board terminal block .....  
③ Check of grounding terminal ..... } See Item 3.4

#### 3. Piping

- ① Check that a piping is filled with fluid.
- ② Check that there is no problem when water stops or flows.

## 4.2 Power ON and status

### (1) Power specification

AC power

Use power supply of 100 to 120VAC or 200 to 240V (50/60 Hz).

### (2) Power ON

**CAUTION** Before turning on the power, check the power specifications again.

When the instrument is turned on, the following data are displayed on the LCD after making a self-check of the devices.

```

  F L H - 3   S Y S T E M
  T I M E   D E L T A   F
  
```



```

  B A C K U P   M E M O R Y
                L O A D I N G
  
```



```

  S t a b i l i t y   W a i t !
  * * * * *
  
```



Measurement display

```

  * -   0 . 0 0 0   m / s
  *     0 . 0 0   m 3 / h
  
```

### (3) Contents displayed on LCD

The numerical values and symbols on LCD means the following:

1st line ①②③④⑤⑥⑦⑧⑨⑩⑪⑫⑬⑭⑮⑯  
 2nd line ①②③④⑤⑥⑦⑧⑨⑩⑪⑫⑬⑭⑮⑯

Digit	Contents
①	Measuring condition (flicker) * : Normal operation ← : Over display digit C : Low-flow cut E : Range over B : Backup error U : Transmission error between modules F : Receiving waveform error
②	Flow direction : Forward direction - : Reverse direction
③ to ⑨	Data display
⑩	Blank
⑪ to ⑯	Units

## 5. SETTING OF PARAMETERS

### 5.1 Outline of operating procedures

Proceed to the following procedure before starting measurements.

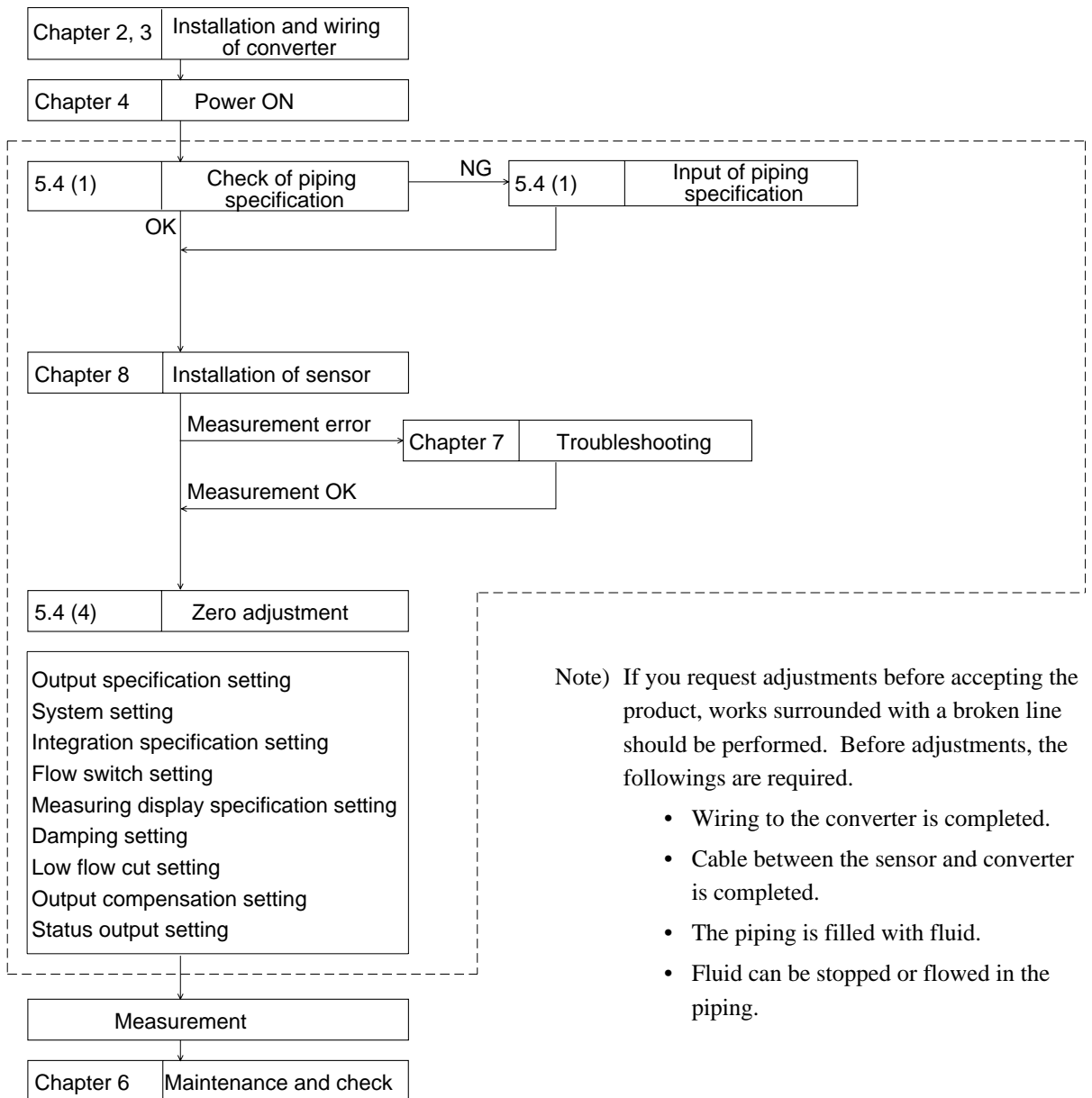

## 5.2 Description of key operation

Note) When adjustment is performed or setting is changed in this Chapter, be sure to enter parameters in the list attached to the converter.

Pressing the **FUNC** key enables you to perform the functions shown on the upper side of the ten-keys.

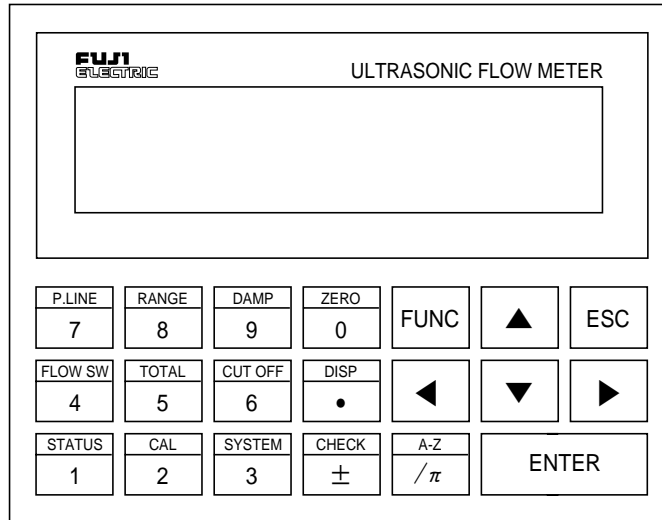

**Description of key (1/2)**

Name	Key display	Description
Ten-keys	0 to 9, •, ±	To enter data and numeric values of piping specifications.
ENTER	ENTER	By pressing this key, numeric data and selected interactive items are set. In the interactive mode, questions are displayed.
◀, ▶	◀, ▶	To move the cursor to correct numeric values. Pressing the ◀ key allows the cursor to be moved to the left. Pressing the ▶ key allows the cursor to be moved to the right. Select the menu item display in an interactive message.
▲, ▼	▲, ▼	Pressing the ▲ key allows the menu page to advance. Pressing the ▼ key allows the menu page to return.
ESCAPE (Stop)	ESC	To stop interactive operation.
FUNC. (Function)	FUNC	To perform the function inscribed on each ten-key.
/π	/π	By pressing this key, the circumference of pipe, which has been entered, is converted into the outside diameter. (valid only when setting the outside diameter of pipe)

### Description of key (2/2)

Name	Key display	Description
PROCESS LINE (Process line)	<b>FUNC</b> <b>P.LINE</b>	To enter the size and material of the sensor piping.
RANGE (Analog output)	<b>FUNC</b> <b>RANGE</b>	To set the condition of an analog output (units, range, limit, burn-out).
DAMPING (Damping)	<b>FUNC</b> <b>DAMP</b>	To set the damping.
ZERO (Zero)	<b>FUNC</b> <b>ZERO</b>	To use when zero adjustment is performed.
DISPLAY (Display panel)	<b>FUNC</b> <b>DISP</b>	Keys used to change items or unit system on the measurement display screen.
CUT OFF (Low flow cut)	<b>FUNC</b> <b>CUT OFF</b>	To set the low flow cut.
TOTAL (Integration)	<b>FUNC</b> <b>TOTAL</b>	To set condition required for integration of flow rate. (units, constant, preset value, integral switch, pulse width)
FLOW SW (Flow switch)	<b>FUNC</b> <b>FLOW SW</b>	To set the measured high/low value switch
STATUS (Status)	<b>FUNC</b> <b>STATUS</b>	To set condition of status output (integration pulse, measuring status).
CAL. (Calibration)	<b>FUNC</b> <b>CAL</b>	To compensate indication values of zero point and 100% point (current output is effected).
SYSTEM (System)	<b>FUNC</b> <b>SYSTEM</b>	To switch the measuring unit system and language, or confirm or calibrate analog output.
CHECK (Check)	<b>FUNC</b> <b>CHECK</b>	To display an error message and countermeasures when an error appears.  (An error message is displayed on the upper-right of the LCD.)

### 5.3 List of setting items

Measurement screen	Piping specifications ----- See Item 5.4 (1)	( <b>FUNC</b> <b>P.LINE</b> )
	Range setting ----- See Item 5.4 (2)	( <b>FUNC</b> <b>RANGE</b> )
	Range ----- See Item 5.4 (2)	
	Output limit ----- See Item 5.4 (2)	
	Burn-out ----- See Item 5.4 (2)	
	Damping ----- See Item 5.4 (3)	( <b>FUNC</b> <b>DAMP</b> )
	Zero adjustment ----- See Item 5.4 (4)	( <b>FUNC</b> <b>ZERO</b> )
	Display setting ----- See Item 5.4 (5)	( <b>FUNC</b> <b>DISP</b> )
	Low flow cut ----- See Item 5.4 (6)	( <b>FUNC</b> <b>CUT OFF</b> )
	Integration ----- See Item 5.4 (7)	( <b>FUNC</b> <b>TOTAL</b> )
	Integration unit and constant ----- See Item 5.4 (7)	
	Integral preset ----- See Item 5.4 (7)	
	Integral switch ----- See Item 5.4 (7)	
Integral pulse width ----- See Item 5.4 (7)		
Flow switch ----- See Item 5.4 (8)	( <b>FUNC</b> <b>FLOW SW</b> )	
Status output ----- See Item 5.4 (9)	( <b>FUNC</b> <b>STATUS</b> )	
Output compensation ----- See Item 5.4 (10)	( <b>FUNC</b> <b>CAL</b> )	
System ----- See Item 5.4 (11)	( <b>FUNC</b> <b>SYSTEM</b> )	
Measuring unit ----- See Item 5.4 (11)		
Switch of language ----- See Item 5.4 (11)		
Confirmation of analog output -- See Item 5.4 (12)		
Setting of BCD interface -- See Item 5.4 (14)		
Setting of measurement mode ----- See Item 5.4 (15)		
Designation of analog output destination ----- See Item 5.4 (16)		

## 5.4 Setting of parameters

- Units are displayed in metric system.

### 5.4 (1) Setting of piping specifications

#### Description

Set the data of pipe required for measurement. The mounting dimension of the sensor is automatically calculated. Data of each item should be entered according to the display.

Item	Entry	Range or menu
Designation of measurement unit	Numeric value	1 to 2
Outside diameter of pipe	Numeric value	13mm to 6100mm
Material of pipe	Selectable	CARBON STEEL, STAINLESS STEEL, PVC, COPPER, CAST IRON, ALUMINUM, FRP, ASBESTOS, DUCTILE IRON, PEEK, PVDF, ACRYLIC, OTHERS*1
Pipe wall thickness	Numeric value	0.1mm to 100mm
Lining (with/without) and material	Selectable	NO LINING, TAR EPOXY, MORTAR, RUBBER, TEFLON, PYREX GLASS, PVC, OTHERS *1
Type of fluid	Selectable	WATER, SEAWATER, OTHERS *1
Dynamic viscosity coefficient of fluid	Numeric value	0.001E-6m <sup>2</sup> /s to 999.999E-6m <sup>2</sup> /s *2
Mounting method of sensor	Selectable	V METHOD, Z METHOD
Type of sensor	Selectable	FLW11, FLW12, FLW32, FLW50, FLW51
Transmission voltage of sensor	Selectable	1 TIME, 2 TIMES, 4 TIMES, 8 TIMES

\*1) Selection of "OTHERS"

Materials of piping and lining should be selected within the range of 1000 to 3700m/s of sound velocity and 500 to 2500m/s of flow velocity (see Appendix).

\*2) Dynamic viscosity coefficient is expressed in water (20°C: 1.0038E-6m<sup>2</sup>/s)

When more accurate data need be obtained or fluid other than water is selected, enter an appropriate data as needed from Appendix.

Operation (example)	To measurement unit Outside diameter:114.3mm, pipe material:carbon steel, thickness:4.5mm, lining material:mortar, thickness:1.25mm, fluid:heavy water, sound velocity : 1388m/s, dynamic viscosity coefficient : $1.129 \times 10^{-6} \text{m}^2/\text{s}$ , sensor mounting method:V method, type : FLW12, Transmission voltage:8 times	
Key operation	Description	Display
<input type="button" value="FUNC"/> <input type="button" value="P.LIPE"/>	Display the "MEASURE-MENT UNIT" screen.	<input type="text" value="PROCESS LINE"/> <input type="text" value="SELECT"/> <input type="text" value="NO. 1"/> <input type="checkbox"/>
<input type="text" value="1"/>	Enter "1".	<input type="text" value="PROCESS LINE"/> <input type="text" value="SELECT"/> <input type="text" value="NO. 1"/> <input type="checkbox"/>
<input type="button" value="ENTER"/>	The sensor mounting dimension is displayed.	<input type="text" value="1: SENSOR SPACING"/> <input type="text" value="32.07 mm V"/>
<input type="button" value="▼"/>	Select "OUTER DIAMETER".	<input type="text" value="1: OUTER DIAMETER"/> <input type="text" value="60.50 mm"/>
<input type="button" value="ENTER"/> <input type="text" value="1"/> <input type="text" value="1"/> <input type="text" value="4"/> <input type="text" value="."/> <input type="text" value="3"/>	Enter "114.3" with ten keys.	<input type="text" value="1: OUTER DIAMETER"/> <input type="text" value="114.3 mm"/>
<input type="button" value="ENTER"/>	Select "PIPE MATERIAL".	<input type="text" value="1: PIPE MATERIAL"/> <input type="text" value="PVC"/>
<input type="button" value="▼"/>	Select "CARBON STEEL".	<input type="text" value="1: PIPE MATERIAL"/> <input type="text" value="CARBON STEEL"/>
<input type="button" value="ENTER"/> <input type="button" value="▲"/> or <input type="button" value="▼"/> <input type="button" value="ENTER"/>	Select "PIPE THICKNESS".	<input type="text" value="1: WALL THICKNESS"/> <input type="text" value="4.28 mm"/>
<input type="button" value="▼"/>	Select "PIPE THICKNESS".	<input type="text" value="1: WALL THICKNESS"/> <input type="text" value="4.28 mm"/>
<input type="button" value="ENTER"/> <input type="text" value="4"/> <input type="text" value="."/> <input type="text" value="5"/> <input type="button" value="ENTER"/>	Enter "4.5" with ten keys.	<input type="text" value="1: WALL THICKNESS"/> <input type="text" value="4.5 mm"/>
<input type="button" value="▼"/>	Select "LINING MATERIAL".	<input type="text" value="1: LINING M."/> <input type="text" value="NO LINING"/>
<input type="button" value="ENTER"/> <input type="button" value="▲"/> or <input type="button" value="▼"/> <input type="button" value="ENTER"/>	Select "MORTAR".	<input type="text" value="1: LINING M."/> <input type="text" value="MORTAR"/>
<input type="button" value="▼"/>	Select "LINING THICKNESS".	<input type="text" value="1: LINING T."/> <input type="text" value="0.10 mm"/>
<input type="button" value="ENTER"/> <input type="text" value="1"/> <input type="text" value="."/> <input type="text" value="2"/> <input type="text" value="5"/> <input type="button" value="ENTER"/>	Enter "1.25" with ten keys.	<input type="text" value="1: LINING T."/> <input type="text" value="1.25 mm"/>
<input type="button" value="▼"/>	Select "KIND OF FLUID".	<input type="text" value="1: KIND OF FLUID"/> <input type="text" value="WATER"/>



Key operation	Description	Display
[ENTER] [▲] or [▼] [ENTER]	Select "OTHERS".	1: KIND OF FLUID OTHERS
[▼]	Select "FLUID S.V.".	1: FLUID S.V. 500.00 m/s
[ENTER] [1] [3] [8] [8] [ENTER]	Enter "1388" with ten keys.	1: FLUID S.V. 1388 m/s
[▼]	Select "VISCOSITY".	1:VISCOSITY 1.0038E-6 m2/s
[ENTER] [1] [.] [1] [2] [9] [ENTER]	Enter "1.129" with ten keys.	1:VISCOSITY 1.129 E-6 m2/s
[▼]	Select "SENSOR MOUNTING".	1:SENSOR MOUNTING V METHOD
[ENTER] [▲] or [▼] [ENTER]	Select "V METHOD".	1:SENSOR MOUNTING V METHOD
[▼]	Select "SENSOR TYPE".	1:SENSOR TYPE FLW12
[ENTER] [▲] or [▼] [ENTER]	Select "FLW12".	1:SENSOR TYPE FLW12
[▼]	Select "TRANS.VOLTAGE".	1:TRANS. VOLTAGE 1 TIME
[ENTER] [▲] or [▼] [ENTER]	SELECT "8 TIMES".	1:TRANS. VOLTAGE 8 TIMES
[▼]	The sensor mounting dimension is displayed.	1:SENSOR SPACING 80.56 mm V
[ESC] [ESC]		(Measurement display)

## 5.4 (2) Setting of range

### Description

The range in which the measured value (flow rate or velocity) is designated to provide an output of 4 to 20 mA.

#### ① Selection of range

The current output destination should be specified according to the current output definition of the system. See 5.4. (16).

See Table for the relation between range selection and data.

Data 1	Setting to the single-path system
Data 2	Setting to the 2-path system
Data 3	Setting to the calculation values

#### ② Selection of range unit

Measurement mode		Data 1	Data 2	Data 3
2-path system	Velocity	m/s	m/s	m/s
	Flow rate	1/s, 1/min, 1/h, M1/d, m3/s, m3/min, m3/h, Mm3/d	1/s, 1/min, 1/h, M1/d, m3/s, m3/min, m3/h, Mm3/d	1/s, 1/min, 1/h, M1/d, m3/s, m3/min, m3/h, Mm3/d
2-pipe system	Velocity	m/s	m/s	—
	Flow rate	1/s, 1/min, 1/h, M1/d, m3/s, m3/min, m3/h, Mm3/d	1/s, 1/min, 1/h, M1/d, m3/s, m3/min, m3/h, Mm3/d	1/s, 1/min, 1/h, M1/d, m3/s, m3/min, m3/h, Mm3/d
Single-path system	Velocity	m/s	None	None
	Flow rate	1/s, 1/min, 1/h, M1/d, m3/s, m3/min, m3/h, Mm3/d	None	None

Note) Units of flow switch, low flow cut and output compensation will also be changed with the selection of the range unit.

#### ③ Selection of range type

The range is selectable from 4 types in Table below.

**BASE SCALE:** Set flow the rate value or flow velocity value for 4 mA output

**FULL SCALE:** Set the flow rate value or flow velocity value for 20 mA output

**HYSTERESIS:** Set the hysteresis as needed when the range is selected. It is expressed with a percentage of the small range span. But, the forward/reverse range is expressed with a percentage of the operation range.

Range type	Range setting range			
	Base scale	Full scale 1	Full scale 2	Hysteresis
Single range	0 to $\pm 32$ m/s	0 to $\pm 32$ m/s	None	None
Auto 2 ranges	0 to $\pm 32$ m/s	0 to $\pm 32$ m/s	0 to $\pm 32$ m/s	0 to 20%
Forward/Reverse range	0 to $\pm 32$ m/s	0 to $\pm 32$ m/s	0 to $\pm 32$ m/s	0 to 20%
Forward/Reverse auto 2 ranges	0 to $\pm 32$ m/s	0 to $\pm 32$ m/s	0 to $\pm 32$ m/s	0 to 20%

Description

• Single range

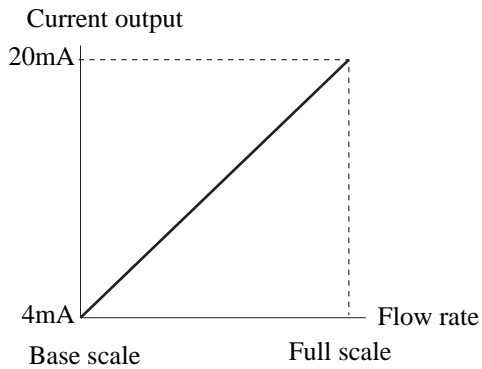

• Auto 2 ranges

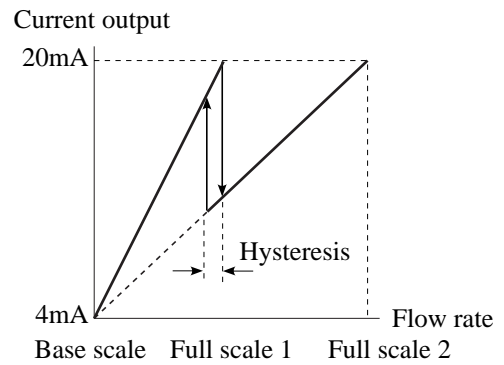

• Forward/Reverse range

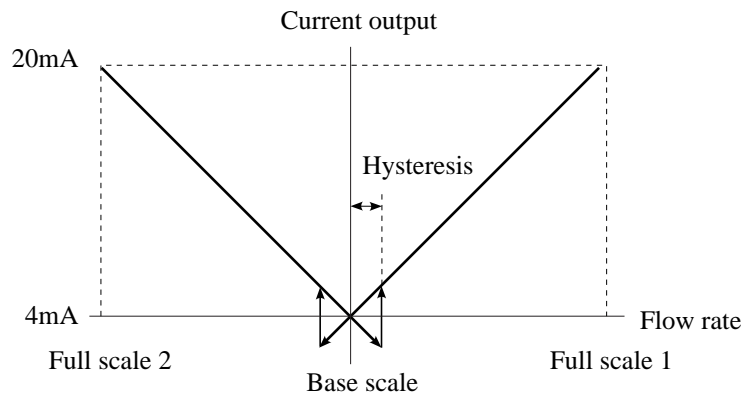

• Forward/Reverse auto 2 ranges

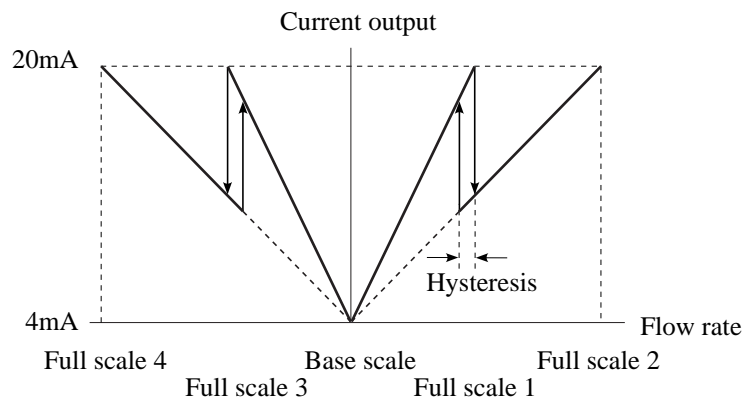

Note 1) Setting full scale 1 and full scale 2 will set full scale 3 and full scale 4 automatically.

Note 2) Relation between full scale 1 and 3, and 2 and 4 is as follows:

$$| (\text{Full scale 1}) - (\text{Base scale}) | = | (\text{Full scale 3}) - (\text{Base scale}) |$$

$$| (\text{Full scale 2}) - (\text{Base scale}) | = | (\text{Full scale 4}) - (\text{Base scale}) |$$

Description

④ Setting of current output limits

The high and low limits are settable within the range of the current output of -20% to 120% (0.8 to 23.2 mA).

• Single range and forward/reverse range

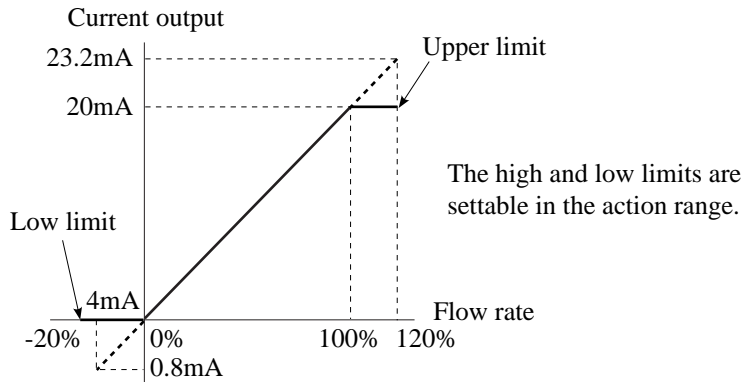

• Auto 2-range and forward/reverse auto 2-range

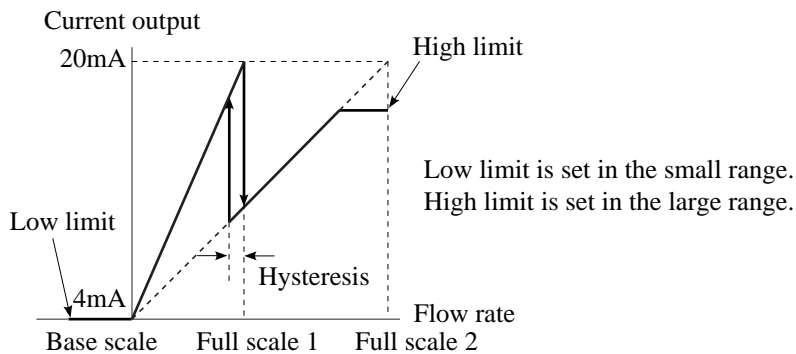

⑤ Setting of burnout

If the pipe is empty of fluid or when air bubbles are contained in fluid, flow rate cannot be measured correctly. In such a case, the flowmeter provides capabilities of setting an output current to special value given below, by setting burnout.

A burnout timer is used to set the time needed for burnout.

Setting of selection	Function	Remarks
HOLD	Holds output current at measured value.	Liquid display: Holds a measured value. Integrated pulse output: Stops integrated pulse output. Internal integration: Stops integration
HIGH LIMIT	Sets an output current to 120% (23.2 mA).	
LOW LIMIT	Sets an output current to -20% (0.8 mA).	
ZERO	Sets an output current to 0% (4.0 mA).	
NO USE	Not used.	

Note) Measured values are integrated until the burnout timer is energized.

Setting range of burnout timer: 0 to 900 sec

Operation (example)	When providing an output of data 3 (average value) as follows: Set the forward/reverse auto range and base scale to 0m <sup>3</sup> /h, full scale 1 to 100m <sup>3</sup> /h , full scale 2 to -100m <sup>3</sup> /h, hysteresis to 5%, low limit to -10% (2.4 mA), high limit to 110% (21.6 mA), burnout to the LOW limit value and burnout timer to 15 sec.	
Key operation	Description	Display
[FUNC] [RANGE]	Display “RANGE” screen.	RANGE SELECT No. 1 ■
[3]	Select “3”.	RANGE SELECT No. 3 ■
[ENTER]	Display “RANGE UNIT”.	3: RANGE UNIT m/s
[ENTER] ▲ or ▼ [ENTER]	Select “m <sup>3</sup> /h”.	3: RANGE UNIT m <sup>3</sup> /h
▼	Select “RANGE TYPE”.	3: RANGE TYPE SINGLE
[ENTER] ▲ or ▼ [ENTER]	Select “Forward/reverse range”.	3: RANGE TYPE BI-DIR
▼	Select “BASE SCALE”.	3: BASE SCALE 0.00 m <sup>3</sup> /h
[ENTER] [0] [ENTER]	Enter “0” with ten keys.	3: BASE SCALE 0 m <sup>3</sup> /h
▼	Select “FULL SCALE 1”.	3: FULL SCALE 1 32.00 m <sup>3</sup> /h
[ENTER] [1] [0] [0] [ENTER]	Enter “100” with ten keys.	3: FULL SCALE 1 100 m <sup>3</sup> /h
▼	Select “FULL SCALE 2”.	3: FULL SCALE 2 32.00 m <sup>3</sup> /h
[ENTER] [-] [1] [0] [0] [ENTER]	Enter “-100” with ten keys.	3: FULL SCALE 2 -100 m <sup>3</sup> /h
▼	Select “RANGE HYSTERESIS”.	3: RANGE HYS. 0.00%
[ENTER] [5] [ENTER]	ENTER “5” with ten keys.	3: RANGE HYS. 5%

Key operation	Description	Display
▼	Select "OUTPUT LOW LIMIT".	3: OUTPUT LIMIT LO 0.00%
ENTER ± 1 0 ENTER	Enter "-10" with ten keys.	3: OUTPUT LIMIT LO -10%
▼	Select "OUTPUT HIGH LIMIT".	3: OUTPUT LIMIT HI 100.00%
ENTER 1 1 0 ENTER	Enter "110" with ten keys.	3: OUTPUT LIMIT HI 110%
▼	Select "BURNOUT".	3: OUTPUT BURNOUT NOT USED
ENTER ▲ or ▼ ENTER	Select "LOW LIMIT".	3: OUTPUT BURNOUT LOWER
▼	Select "BURNOUT TIMER".	3: BURNOUT TIMER 0.00 sec
ENTER 1 5 ENTER	Enter "15" with ten keys.	3: BURNOUT TIMER 15 sec
ESC ESC		(Measurement display)

### 5.4 (3) Setting of damping

#### Description

Damping is used to suppress fluctuation of measured values.

The set value is a time constant (about 63% response time). (Setting range : 0 to 100 sec)

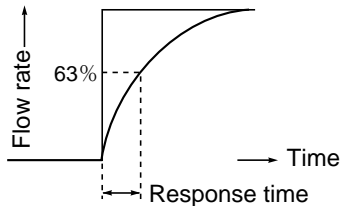

	Measurement mode		
	2-path system	2-pipe system	Single-path system
Data 1	○	○	○
Data 2	○	○	—
Data 3	○	—	—

Unless otherwise specified in the order sheet, the setting time of damping is adjusted to 5 sec.

Operation (example)		When multiplying data 3 (average value) by a damping of 20 sec with a time constant set to 20 sec:	
Key operation	Description	Display	
<b>FUNC</b> <b>DAMP</b>	Display the “DAMPING” screen.	<div style="border: 1px solid black; padding: 5px; text-align: center;">           DAMPING            SELECT No. 1 ■         </div>	
<b>3</b>	Enter “3”.	<div style="border: 1px solid black; padding: 5px; text-align: center;">           DAMPING            SELECT No. 3 ■         </div>	
<b>ENTER</b>	Display “DAMPING”.	<div style="border: 1px solid black; padding: 5px; text-align: center;">           3: DAMPING            0.00 sec         </div>	
<b>ENTER</b> <b>2</b> <b>0</b> <b>ENTER</b>	Enter “20” with ten keys.	<div style="border: 1px solid black; padding: 5px; text-align: center;">           3: DAMPING            20 sec         </div>	
<b>ESC</b> <b>ESC</b>		<div style="border: 1px solid black; padding: 5px; text-align: center;">           (Measurement display)         </div>	

## 5.4 (4) Zero adjustment

### Description

Zero point of measured value is adjusted.

(Setting items)

- ZERO POINT ADJUST : Stop the flow of fluid and adjust zero point.  
The zero point is the state of measurement at set point.
- ZERO POINT CLEAR : This setting is used when fluid does not stop flowing.  
Adjusted zero point is cleared.

	Measurement mode		
	2-path system	2-pipe system	Single-path system
Data 1	○	○	○
Data 2	○	○	—
Data 3	—	—	—

Operation (example)	Zero point adjustment when fluid is in stop mode.	
Key operation	Description	Display
<div style="border: 1px solid black; padding: 2px; display: inline-block;">FUNC</div> <div style="border: 1px solid black; padding: 2px; display: inline-block;">ZERO</div>	Display the “ZERO POINT MODE” screen.	<div style="border: 1px solid black; padding: 5px; text-align: center;">           Z-PROCESS LINE            SELECT No. 1 ■         </div>
<div style="border: 1px solid black; padding: 2px; display: inline-block;">1</div>	Enter “1”.	<div style="border: 1px solid black; padding: 5px; text-align: center;">           Z-PROCESS LINE            SELECT No. 1 ■         </div>
<div style="border: 1px solid black; padding: 2px; display: inline-block;">ENTER</div>	Display “ZERO POINT MODE”.	<div style="border: 1px solid black; padding: 5px; text-align: center;">           1: PROCESS LINE            CLEAR         </div>
<div style="border: 1px solid black; padding: 2px; display: inline-block;">ENTER</div> <div style="border: 1px solid black; padding: 2px; display: inline-block; margin: 0 5px;">▲</div> or <div style="border: 1px solid black; padding: 2px; display: inline-block; margin: 0 5px;">▼</div> <div style="border: 1px solid black; padding: 2px; display: inline-block; margin-left: 5px;">ENTER</div>	Select “Zero point adjustment”.	<div style="border: 1px solid black; padding: 5px; text-align: center;">           1: PROCESS LINE            ZERO         </div>
	The right screen is displayed for about 10 sec.	<div style="border: 1px solid black; padding: 5px; text-align: center;">           1: PROCESS LINE            *****         </div>
<div style="border: 1px solid black; padding: 2px; display: inline-block;">ESC</div> <div style="border: 1px solid black; padding: 2px; display: inline-block; margin-left: 5px;">ESC</div>	If a mark of * disappear, adjustment is completed.	<div style="border: 1px solid black; padding: 5px; text-align: center;">           (Measurement display)         </div>

Note) Measuring units 1 and 2 should be zero-calibrated, and zero calibration should be performed by displaying their measured values.



## 5.4 (5) Setting of measurement display specifications

### Description

Select measured value from the following.

① The display below can be made by “Display mode”.

Measurement mode	1st line	2nd line
	1st line: Single-path system, 2-path system and selection data for calculation is displayed 2nd line: The flow rate unit on the 1st line is displayed.	
2-path system	<ul style="list-style-type: none"> <li>• Flow velocity</li> <li>• Forward integral value</li> <li>• Reverse integral value</li> <li>• F integral pulse</li> <li>• R integral pulse</li> <li>• AO range %</li> </ul>	[Flow rate unit display] l/s, 1/min, 1/h, M1/d m3/s, m3/min, m3/h, Mm3/d
2-pipe system	1st line: Selection data of single-path system is displayed. 2nd line: Selection data of 2-path system is displayed	
	<ul style="list-style-type: none"> <li>• Flow velocity</li> <li>• Flow rate (select one from the units)</li> <li>• Forward integral value</li> <li>• Reverse integral value</li> <li>• F integral pulse</li> <li>• R integral pulse</li> <li>• AO range %</li> </ul>	<ul style="list-style-type: none"> <li>• Flow velocity</li> <li>• Forward integral value (select one from the units)</li> <li>• Forward integral value</li> <li>• Reverse integral value</li> <li>• F integral pulse</li> <li>• R integral pulse</li> <li>• AO range %</li> </ul>
Single-path system	1st line: Selection data is displayed. 2nd line: Flow rate unit is displayed.	
	<ul style="list-style-type: none"> <li>• Flow velocity</li> <li>• Forward integral value</li> <li>• Reverse integral value</li> <li>• F integral pulse</li> <li>• R integral pulse</li> <li>• AO range %</li> </ul>	[Flow rate unit display] l/s, 1/min, 1/h, M1/d m3/s, m3/min, m3/h, Mm3/d

- Flow velocity: Instantaneous flow velocity
- Forward integral value: Forward integral value
- Reverse integral value: Reverse integral value
- F integral pulse: Forward integral pulse
- R integral pulse: Reverse integral pulse
- AO range %: Ratio of analog output to setting range

② Setting of decimal place of numerical value

Measured data is displayed in 7 digits (including decimal point).

Decimal place can be put at any position within 7 digits.

Operation (example)	Display the value in data 3 (average value), instantaneous flow velocity and instantaneous flow unit in m <sup>3</sup> /h, and instantaneous flow rate in 3rd decimal places.	
Key operation	Description	Display
<b>FUNC</b> <b>DISP</b>	Display the “DISPLAY” screen.	<pre> DISPLAY SELECT No.1 █ </pre>
<b>3</b> <b>ENTER</b>	Enter "3".	<pre> DISPLAY SELECT No.3 █ </pre>
<b>ENTER</b>	The display is ready to select.	<pre> 3: DISPLAY KIND AO RANGE % </pre>
<b>▲</b> or <b>▼</b> , <b>ENTER</b>	Select “VELOCITY”.	<pre> 3: DISPLAY KIND VELOCITY </pre>
<b>▲</b> or <b>▼</b> , <b>ENTER</b>	Display “DISPLAY UNIT”.	<pre> 3: DISPLAY UNIT m3 / s </pre>
<b>▲</b> or <b>▼</b> , <b>ENTER</b>	Select “m3/h”.	<pre> 3: DISPLAY UNIT m3 / h </pre>
<b>ESC</b> <b>ESC</b> <b>ESC</b>	Move to the “MEASUREMENT” screen.	<pre> *      12. 34  m / s       123. 45  m3 / h </pre>
<b>FUNC</b> <b>▼</b>	Select the 2nd line. (Press the <b>▲</b> button to display the first line.)	<pre> *      12. 34  m / s █      123. 45  m3 / h </pre>
<b>◀</b> or <b>▶</b>	Set the decimal place (by pressing <b>▲</b> button once).	<pre> *      12. 34  m / s █      123. 456 m3 / h </pre>
<b>ENTER</b> or <b>ESC</b>	Move to the Measurement display.	<pre> *      12. 34  m / s       123. 456 m3 / h </pre>

Note) When an arrow of “←” is displayed on the “MEASUREMENT DISPLAY” screen, the number of the digits is more than 7.

## 5.4 (6) Low flow output cut

### Description

A low flow output can be cut.

This flowmeter will display the flow rate, when the fluid in the piping is moving with the valve closed due to a convection current. The cutting point should be set as needed.

(Setting range : 0 to 5m/s in terms of flow velocity value)

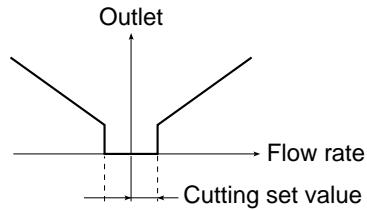

	Measurement mode		
	2-path system	2-pipe syste	Single-path system
Data 1	○	○	○
Data 2	○	○	—
Data 3	○	—	—

Operation (example)	Setting of a cutting point of data 3 (average value) to 0.05 m/s		
Key operation	Description	Display	
<b>FUNC</b> <b>CUT OFF</b>	Display the “CUT OFF” screen.	<div style="border: 1px solid black; padding: 5px; text-align: center;">           CUT OFF            SELECT No. 1 ■         </div>	
<b>1</b>	Enter “3” with ten keys.	<div style="border: 1px solid black; padding: 5px; text-align: center;">           CUT OFF            SELECT No. 3 ■         </div>	
<b>ENTER</b>	Display “CUT OFF”.	<div style="border: 1px solid black; padding: 5px; text-align: center;">           3: CUT OFF            0.00 m/s         </div>	
<b>ENTER</b> <b>0</b> <b>.</b> <b>0</b> <b>5</b> ,	Enter “0.05” with ten keys.	<div style="border: 1px solid black; padding: 5px; text-align: center;">           3: CUT OFF            0.05 m/s         </div>	
<b>ENTER</b>			
<b>ESC</b> <b>ESC</b>		<div style="border: 1px solid black; padding: 5px; text-align: center;">           (Measurement display)         </div>	

## 5.4 (7) Setting of integrated output unit and constant

### Description

Integrated output unit is set to integrate measurement value (flow rate)

① Selection of output value.....

Items to be selected	Contents	Measurement mode		
		2-path system	2-pipe syste	Single-path system
Data 1	Single-path	○	○	○
Data 2	2-path	○	○	—
Data 3	Calculation values (average, addition, reduction)	○	○	—

② Integrated unit.....Select one of the following 4 kinds of integral units.

- mL, L, m<sup>3</sup>, Mm<sup>3</sup>

Note : When changing the integrated unit, integral constant value and integral preset value are cleared.

③ Integral constant

When the flow rate reaches the value set by the integral constant, integral pulse value is displayed on the measurement screen, and the integral pulse counter provides an output of 1 pulse.

Setting range : 0 to 9999999

④ Integrated preset value.....Sets a preset value for integration start.

- F: TOTAL PRESET: Forward integral preset value
- R: TOTAL PRESET: Reverse integral preset value

Setting range : 0 to 9999999

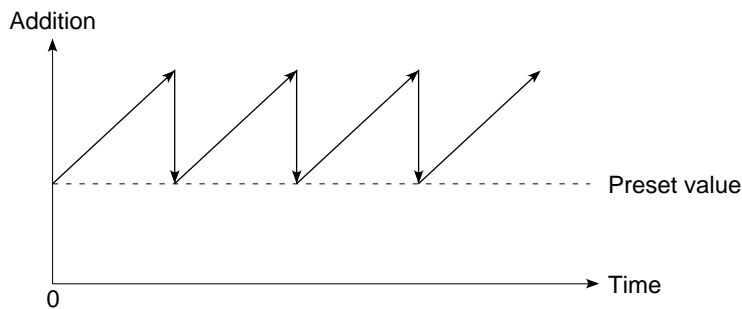

Note : In case of setting, please keep “TOTAL MODE” suspended.

- ⑤ Integration switch.....Provides status outputs when an integral value exceeds the set value.
- F: TOTAL PRESET: Forward integral switch
  - R: TOTAL PRESET: Reverse integral switch
- Setting range : 0 to 9999999

Note : When setting the status output, integration switch is valid only when “F : TOTAL SW” or “R : TOTAL SW” is set.

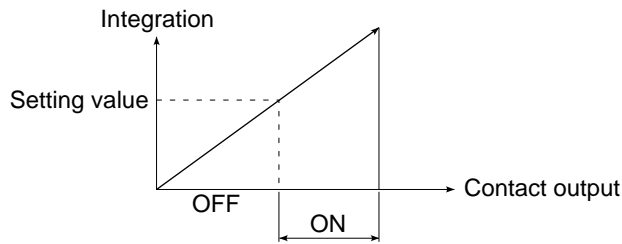

Note: In case of setting, keep “TOTAL MADE” suspended.

- ⑥ Pulse width.....The following 2 types can be selected according to the counter connected.
- When setting status output, set the pulse width to use "F: TOTAL PULSE" or "R: TOTAL PULSE"
- 50msec
  - 100msec

Note : In case of setting, keep “TOTAL MODE” suspended.

Operation (example)	When setting an average value of the 2-path system as follows: Set the integral constant to 10m <sup>3</sup> , forward preset value to 1000 m <sup>3</sup> , backward preset value to 200 m <sup>3</sup> , forward integration switch set value to 50000 m <sup>3</sup> , reverse integration switch set value to 10000 m <sup>3</sup> and pulse width to 100 msec.			
Key operation	Description	Display		
[FUNC] [TOTAL]	Display “TOTAL” screen.	<table border="1" style="width: 100%; text-align: center;"> <tr> <td>TOTAL</td> </tr> <tr> <td>SELECT No. 1</td> </tr> </table>	TOTAL	SELECT No. 1
TOTAL				
SELECT No. 1				
[3]	Enter “3”.	<table border="1" style="width: 100%; text-align: center;"> <tr> <td>TOTAL</td> </tr> <tr> <td>SELECT No. 3</td> </tr> </table>	TOTAL	SELECT No. 3
TOTAL				
SELECT No. 3				
[ENTER]	Display “TOTAL MODE”.	<table border="1" style="width: 100%; text-align: center;"> <tr> <td>3: TOTAL MODE</td> </tr> <tr> <td>TOTAL RUN</td> </tr> </table>	3: TOTAL MODE	TOTAL RUN
3: TOTAL MODE				
TOTAL RUN				
[ENTER] [▲] or [▼] [ENTER]	Select “TOTAL STOP”.	<table border="1" style="width: 100%; text-align: center;"> <tr> <td>3: TOTAL MODE</td> </tr> <tr> <td>TOTAL STOP</td> </tr> </table>	3: TOTAL MODE	TOTAL STOP
3: TOTAL MODE				
TOTAL STOP				

Key operation	Description	Display
▼	Select "TOTAL UNIT".	3: TOTAL UNIT m1
ENTER ▲ or ▼, ENTER	Select "m <sup>3</sup> ".	3: TOTAL UNIT m3
▼	Select "TOTAL RATE".	3: TOTAL RATE 0 m3
ENTER 1 0 ENTER	Enter "10" with ten keys.	3: TOTAL RATE 10 m3
▼	Select "F TOTAL PRESET".	3: F TOTAL PRESET 0 m3
ENTER 1 0 0 0	Enter "1000" with ten keys.	3: F TOTAL PRESET 1000 m3
▼	Select "F TOTAL SW".	3: F TOTAL SW 0 m3
ENTER 5 0 0 0 0 ENTER	Enter "50000" with ten keys.	3: F TOTAL SW 5000 m3
▼	Select "R TOTAL PRESET":	3: R TOTAL PRESET 0 m3
ENTER 2 0 0 ENTER	Enter "200" with ten keys.	3: R TOTAL PRESET 200 m3
▼	Select "R TOTAL SW".	3: R TOTAL SW 0 m3
ENTER 1 0 0 0 0 ENTER	Enter "10000" with ten keys.	3: R TOTAL SW 10000 m3
▼	Select "PLUSE WIDTH"	3: PULSE WIDTH 50m sec
ENTER ▲ or ▼, ENTER	Select "100 msec"	3: PULSE WIDTH 100m sec

Key operation	Description	Display
<div style="border: 1px solid black; width: 20px; height: 20px; margin-bottom: 10px; display: flex; align-items: center; justify-content: center;">▼</div> <div style="border: 1px solid black; padding: 2px; display: inline-block; margin-right: 5px;">ENTER</div> <div style="border: 1px solid black; width: 20px; height: 20px; display: flex; align-items: center; justify-content: center; margin: 0 5px;">▲</div> <div style="font-size: 10px;">or</div> <div style="border: 1px solid black; width: 20px; height: 20px; display: flex; align-items: center; justify-content: center; margin: 0 5px;">▼</div> <div style="border: 1px solid black; padding: 2px; display: inline-block; margin-right: 10px;">ENTER</div> <div style="border: 1px solid black; padding: 2px; display: inline-block; margin-right: 5px;">ESC</div> <div style="border: 1px solid black; padding: 2px; display: inline-block;">ESC</div>	<p>Display “TOTAL MODE”</p> <p>Select “TOTAL RUN”.</p>	<div style="border: 1px solid black; padding: 5px; text-align: center;"> 3: TOTAL MODE  TOTAL STOP </div> <div style="border: 1px solid black; padding: 5px; text-align: center;"> 3: TOTAL MODE  TOTAL RUN </div> <div style="border: 1px solid black; padding: 5px; text-align: center;"> (Measurement display) </div>

When the flowmeter is restored from the power interruption, it will be started in the same integral mode as set before power interruption.

Note: If there is something wrong with the flowmeter during measurement, refer to burnout setting for integration.

## 5.4 (8) Setting of measured value high and low limit switch

### Description

① Selection of output value.....

Items to be selected	Contents	Measurement mode		
		2-path system	2-pipe syste	
Data 1	Single-path	○	○	○
Data 2	2-path	○	○	—
Data 3	Calculation values (average, addition, reduction)	○	○	—

② Set high limit and low limit of switching point when using high limit flow or low limit flow to set the status output.

Setting range : 0 to  $\pm 32\text{m/s}$  of flow velocity

[Relation between status output and set value]

• High limit setting and high limit flow

• Low limit setting and low limit flow

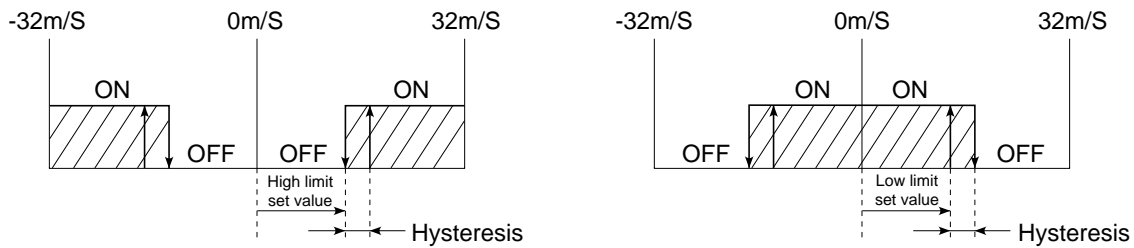

③ Setting of hysteresis

Switching hysteresis can be held in the following range:

Setting range: 0 to 20% (ratio of operation range to span)



Operation (example)	Set the low limit flow velocity to 3.5 m/s, high limit flow velocity to 12 m/s and hysteresis to 5% for the average value of the 2-path system.	
Key operation	Description	Display
<input type="button" value="FUNC"/> <input type="button" value="FLOW SW"/>	Display the "FLOW SW" screen.	<div style="border: 1px solid black; padding: 5px;">           FLOW SW            SELECT No.1 █         </div>
<input type="button" value="3"/>	Enter "3" with ten keys.	<div style="border: 1px solid black; padding: 5px;">           FLOW SW            SELECT No.3 █         </div>
<input type="button" value="ENTER"/>	Display "FLOW SW LOW"	<div style="border: 1px solid black; padding: 5px;">           FLOW SW LOW            0.00 m/s         </div>
<input type="button" value="ENTER"/> <input type="button" value="3"/> <input type="button" value="."/> <input type="button" value="5"/>	Enter "3.5" with ten keys.	<div style="border: 1px solid black; padding: 5px;">           FLOW SW LOW            3.5 m/s         </div>
<input type="button" value="ENTER"/>		<div style="border: 1px solid black; padding: 5px;">           FLOW SW LOW            3.5 m/s         </div>
<input type="button" value="▼"/>	Select "FLOW SW HIGH"	<div style="border: 1px solid black; padding: 5px;">           FLOW SW HIGH            32.00 m/s         </div>
<input type="button" value="ENTER"/> <input type="button" value="1"/> <input type="button" value="2"/> <input type="button" value="ENTER"/>	Enter "12" with ten keys.	<div style="border: 1px solid black; padding: 5px;">           FLOW SW HIGH            12 m/s         </div>
<input type="button" value="▼"/>	Display "FLOW SW HYS."	<div style="border: 1px solid black; padding: 5px;">           FLOW SW HYS.            0.00 %         </div>
<input type="button" value="ENTER"/> <input type="button" value="5"/> <input type="button" value="ENTER"/>	Enter "5" with ten keys.	<div style="border: 1px solid black; padding: 5px;">           FLOW SW HYS            5 m/s         </div>
<input type="button" value="ESC"/> <input type="button" value="ESC"/> <input type="button" value="ESC"/>		<div style="border: 1px solid black; padding: 5px;">           (Measurement display)         </div>

## 5.4 (9) Setting of status output

### Description

- Set the status output when the status of setting or integral pulse is outputted.
- Provide the status output by the DO output destination and contents with code.

Code	Message	Contents
000	NOT USED	No output
*01	MEASUREMENT ERROR	Measurement error (ON at no signal, the range signal receiving is over)
*02	F: TOTAL PULSE:	Forward flow integral pulse
*03	R: TOTAL PULSE	Reverse flow integral pulse
*04	F: TOTAL SW	ON when exceeding the forward flow integral switch
*05	R: TOTAL SW	ON when exceeding the reverse flow integral switch
*06	F: TOTAL OVERFLOW:	ON when overflowing the forward flow integral value.
*07	R: TOTAL OVERFLOW	ON when overflowing the reverse flow integral value
*08	FLOW HIGH	ON when the flow switch exceeds the high limit setting.
*09	FLOW LOW	ON when the flow switch is below the low limit setting
*10	RANGE FULL SCALE 2	ON when analog output is at FULL SCALE 2.
*11	RANGE OVER	ON when exceeding the range of -10 to 110% with respect to the range setting span.
*12	PULSE RANGE OVER	ON when the integral pulse output exceeds 5 pulses/sec.
*13	BACKUP ABNORMAL	ON when the backup non-volatile memory is abnormal.
*14	R: FLOW DIRECTION:	ON when the flow direction is reverse.

\* For the item with an asterisk mark of \*, enter numerical values of 1 to 3.

- 1: Data 1 (information on the single-path system)
- 2: Data 2 (information on the 2-path system)
- 3: Data 3 (information on calculation results of single-path and 2-path systems)

Note: Only DO31 and DO32 of integral pulses are valid.

- Measurement mode and selectable status output

Measurement mode	Status output					
	DO11	DO12	DO21	DO22	DO31	DO32
2-path system	○	○	○	○	○	○
2-pipe system	○	○	○	○	○	○
Single-path system	○	○	—	—	○	○

- Setting of status output mode

Normal	Set the transistor to ON during operation
Spot	Set the transistor to OFF during operation

Operation (example)	Set the forward flow integral pulse and status output of data 3 to DO31 in the inverse mode	
Key operation	Description	Display
[FUNC] [STATUS]	Move to "STATUS SELECT".	<div style="border: 1px solid black; padding: 5px; text-align: center;">           STATUS SELECT DO 11         </div>
[ENTER]	The screen is ready for entry.	<div style="border: 1px solid black; padding: 5px; text-align: center;">           STATUS SELECT DO 11 █         </div>
3 1 [ENTER]	Enter "31".	<div style="border: 1px solid black; padding: 5px; text-align: center;">           STATUS SELECT DO 31         </div>
▼	Move to "STATUS CODE".	<div style="border: 1px solid black; padding: 5px; text-align: center;">           STATUS CODE No. 000         </div>
[ENTER]	The screen is ready for entry.	<div style="border: 1px solid black; padding: 5px; text-align: center;">           STATUS CODE No. 000         </div>
3 0 2 [ENTER]	Enter "STATUS CODE No. 302". (F: TOTAL PULSE)	<div style="border: 1px solid black; padding: 5px; text-align: center;">           STATUS CODE No. 302         </div>
▼	Move to "STATUS MODE".	<div style="border: 1px solid black; padding: 5px; text-align: center;">           STATUS MODE NORMAL         </div>
[ENTER]	The screen is ready for selection.	<div style="border: 1px solid black; padding: 5px; text-align: center;">           STATUS MODE NORMAL █         </div>
◀ or ▶, [ENTER]	Select "REVERSE".	<div style="border: 1px solid black; padding: 5px; text-align: center;">           STATUS MODE REVERSE         </div>
[ESC] [ESC]	Move to "Measurement display"	<div style="border: 1px solid black; padding: 5px; text-align: center;">           (Measurement display)         </div>

## 5.4 (10) Calibration of measured value

### Description

Measured value (zero and span points) can be calibrated, if required.

Zero point and span point can be calibrated.

Calibration range : Zero point :  $\pm 5\text{m/s}$  of flow velocity

Span :  $\pm 200\%$

Measured value and analog output value are calculated by the following formula.

$$\text{Output} = \frac{\text{Measured value} \times [\text{span set value \%}]}{100} + \text{Zero point}$$

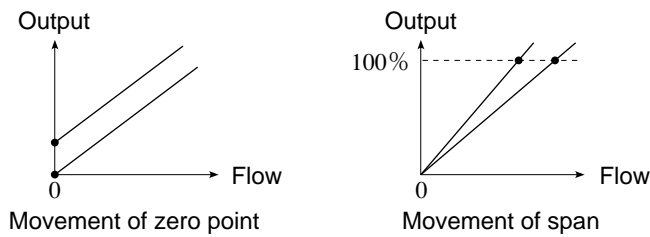

	Measurement mode		
	2-path system	2-pipe syste	Single-path system
Data 1	○	○	○
Data 2	○	○	—
Data 3	○	—	—

Operation (example)	Description	Display
<b>FUNC</b> <b>CAL</b>	Display "CALBRATION" screen.	CALBRATION SELECT No. 1 █
<b>3</b>	Enter "3" with ten keys.	CALBRATION SELECT No. 3 █
<b>ENTER</b>	Display "CAL. ZERO".	CAL. ZERO 0.00 m/s
<b>ENTER</b> <b>-</b> <b>0</b> <b>.</b> <b>5</b>	Enter "-0.5" with ten keys.	CAL. ZERO -0.5 m/s
<b>ENTER</b>	Display "CAL. SPAN"	CAL. SPAN 100.00 %
<b>ENTER</b> <b>1</b> <b>0</b> <b>5</b>	Enter "105" with ten keys.	CAL. SPAN 105 %
<b>ENTER</b>		(Measurement display)
<b>ESC</b> <b>ESC</b> <b>ESC</b>		

## 5.4 (11) Selection of language (English/Japanese)

Description

Japanese or English is selectable where appropriate.

Operation (example) Selection of English display		
Key operation	Description	Display
<b>FUNC</b> <b>SYSTEM</b>	Display the “UNIT & LANGUAGE” screen.	UNIT & LANGUAGE SKIP
<b>ENTER</b> <b>▲</b> or <b>▼</b> <b>ENTER</b>	Select “SETTING”.	UNIT & LANGUAGE SETTING
<b>▲</b> or <b>▼</b> <b>ENTER</b>	Select “LANGUAGE”.	SYS. LANGUAGE JAPANESE
<b>▲</b> or <b>▼</b> <b>ENTER</b>	Select “ENGLISH”.	SYS. LANGUAGE ENGLISH
<b>ESC</b> <b>ESC</b> <b>ESC</b>		(Measurement display)

## 5.4 (12) Analog output check

### Description

The analog output is calibrated so that the measured flow rate is set to provide an output of 4 mA in the base scale and 20mA in the full scale. Calibration to ensure that an ammeter is properly connected to the analog output terminals as shown below.

Check for analog output.

Check that an output value of -20% to 120% is within a range of 0.8 mA to 23.2 mA. Check to ensure that an ammeter is properly connected to the analog output terminals as shown below.

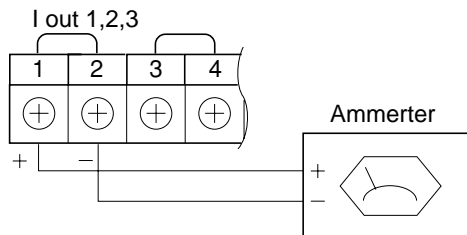

Operation (example)	Calibration of current output (Iout3) and check of 75% output (16mA)	
Key operation	Description	Display
<b>FUNC</b> <b>SYSTEM</b>	Move to the “SYSTEM” screen.	UNIT & LANGUAGE SKIP
<b>▼</b> or <b>▲</b> <b>ENTER</b>	Select “MAINTENANCE”.	MAINTENANCE SKIP
<b>ENTER</b>	The screen is ready for selection.	MAINTENANCE SKIP
<b>▼</b> or <b>▲</b> <b>ENTER</b>	Select “A-out”.	MAINTENANCE A-OUT
<b>3</b> <b>ENTER</b>	Enter “3”.	AO PORT SELECT I out 3 ■
<b>▼</b> (Decrease) or <b>▲</b> (Increase) <b>ENTER</b>	Coarse calibration } Ammeter should Fine calibration } indicate 4mA.	3: AO ADJUST 4 mA
<b>◀</b> (Decrease) or <b>▶</b> (Increase)	Coarse calibration } Ammeter should Fine calibration } indicate 20mA.	3: AO ADJUST 20 mA
		3: AO ADJUST 20 mA

Key operation	Description	Display
[ENTER]	The screen is ready to enter numerical values.	<div style="border: 1px solid black; padding: 5px;">           3: AO CHECK  <div style="text-align: right;">0 %</div> </div>
[ENTER]		<div style="border: 1px solid black; padding: 5px;">           3: AO CHECK  <div style="text-align: right;">0 █ %</div> </div>
[7] [5] [ENTER]	Enter "75" (confirm 16mA.)	<div style="border: 1px solid black; padding: 5px;">           3: AO CHECK  <div style="text-align: right;">75 %</div> </div>
[ESC] [ESC] [ESC] [ESC]	Move to "Measurement display".	<div style="border: 1px solid black; padding: 5px;">           (Measurement display)         </div>

## 5.4 (13) Status output check

### Description

Check the ON-OFF operation of the status output. The status output is an open collector. Check to ensure that a voltmeter is properly connected to DO\*1 and DO\*2 terminals as shown below.

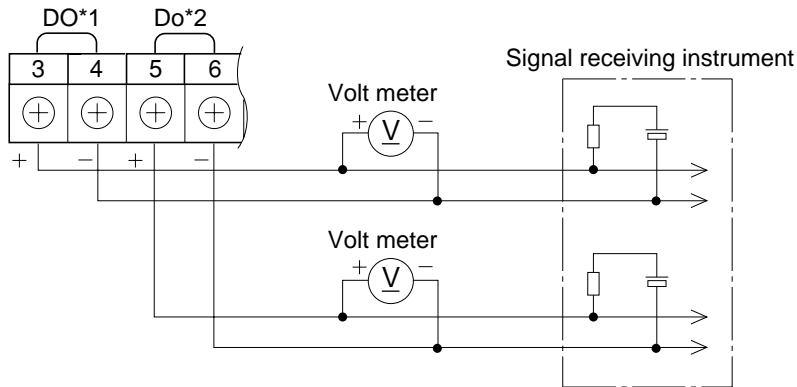

Operation (example)	Check for the DO31 action at the status output.	
Key operation	Description	Display
<b>FUNC</b> <b>SYSTEM</b>	Move to the “System” screen.	UNIT & LANGUAGE SKIP
<b>▲</b> or <b>▼</b> <b>ENTER</b>	Select “MAINTENANCE”.	MAINTENANCE SKIP
<b>ENTER</b>	Display is ready to select.	MAINTENANCE SKIP
<b>◀</b> or <b>▶</b> <b>ENTER</b>	Select “D-OUT”.	MAINTENANCE D-OUT
<b>ENTER</b>	Display is ready to enter.	DO PORT SELECT DO 11 ■
<b>3</b> <b>1</b> <b>ENTER</b>	Select “31”.	DO PORT SELECT DO 31
<b>◀</b> or <b>▶</b> <b>ENTER</b>	Select “ON or OFF”.	31: DO CHECK OFF
<b>ESC</b> <b>ESC</b> <b>ESC</b> <b>ESC</b>	Move to the “Measurement display”.	(Measurement display)



## 5.4 (14) Setting of BCD interface

### Description

Set measured values (instantaneous flow rate) or integral values at the BCD output.

Note : During measurement, set the test mode to “NOT USED”.

Setting items	Contents																			
BCD interval	Set a renewed cycle of the BCD output. Setting range: 0 to 100 sec (in 1 sec unit) Note) When setting the time to “0”, a renewal time is about 0.2 sec.																			
BCD OUTPUT TYPE	Any of instantaneous flow rate, forward integral value and reverse integral value can be selected. <table border="1" style="margin-left: auto; margin-right: auto;"> <thead> <tr> <th rowspan="2"></th> <th colspan="3">Measurement mode</th> </tr> <tr> <th>2-path system</th> <th>2-pipe system</th> <th>Single-path system</th> </tr> </thead> <tbody> <tr> <td>Data 1</td> <td style="text-align: center;"><input type="radio"/></td> <td style="text-align: center;"><input type="radio"/></td> <td style="text-align: center;"><input type="radio"/></td> </tr> <tr> <td>Data 2</td> <td style="text-align: center;"><input type="radio"/></td> <td style="text-align: center;"><input type="radio"/></td> <td style="text-align: center;">—</td> </tr> <tr> <td>Data 3</td> <td style="text-align: center;"><input type="radio"/></td> <td style="text-align: center;"><input type="radio"/></td> <td style="text-align: center;">—</td> </tr> </tbody> </table>		Measurement mode			2-path system	2-pipe system	Single-path system	Data 1	<input type="radio"/>	<input type="radio"/>	<input type="radio"/>	Data 2	<input type="radio"/>	<input type="radio"/>	—	Data 3	<input type="radio"/>	<input type="radio"/>	—
	Measurement mode																			
	2-path system	2-pipe system	Single-path system																	
Data 1	<input type="radio"/>	<input type="radio"/>	<input type="radio"/>																	
Data 2	<input type="radio"/>	<input type="radio"/>	—																	
Data 3	<input type="radio"/>	<input type="radio"/>	—																	
BCD UNIT	Unit of flow rate:L/s, L/min, L/h, ML/d, m3/d, m3/s, m3/min,m3/h,Mm3/d Unit of integral value is changed with the setting of integration output (see 5.5(7)).																			
HIGH LIMIT	Set the high limit value of the BCD output. An output is limited to the high limit value. Setting range: 0 to ±999999 Note) The set value is subject to change when the unit is changed.																			
LOW LIMIT	Set the low limit value of the BCD output. An output is limited to the low limit value. Setting range: 0 to ±999999 Note) The set value is subject to change when the unit is changed.																			
ZERO SUPPRESS	Set the presence or absence of zero display of the upper digits. (Output data: Example of 123 m3/h) ZERO SUPPRESS: NO → 000123 ZERO SUPPRESS: YES → FFF123 (“F” is not displayed with the BCD display.)																			
DECIMAL PLACE	Output the following data to the right of the decimal point specified Setting range: none, 1, 2, 3, 4 and 5 Output data: Example: 123.456 m3/h Without decimal place 000123 Third decimal place 123456																			

Operation (example)	An output of Data 3 (average value) in units of instantaneous flow rate: m3/h, high limit of 5000: m3/h, low limit: 10m3/h, decimal place: 2, zero suppression: ON, interval: 5 sec.	
Key operation	Description	Display
[FUNC] [SYSTEM] ▲ or ▼	Display the “BCD INTERFACE” screen.	BCD INTERFACE SKIP
[ENTER] ▲ or ▼ [ENTER]	Select “SETTING”.	BCD INTERFACE SETTING
[ENTER] 3 [ENTER]	Select “DATA 3”.	BCD OUTPUT DATA No. 3
▲ or ▼ [ENTER]	Display “BCD INTERVAL”.	BCD INTERVAL 2 sec
5 [ENTER]	Select “5”.	BCD INTERVAL 5 sec
▲ or ▼ [ENTER]	Display “BCD KIND FLOW”.	BCD KIND FLOW
▲ or ▼ [ENTER]	Select “FLOW”.	BCD KIND FLOW
▲ or ▼ [ENTER]	Display “BCD UNIT”.	BCD UNIT m3/s
▲ or ▼ [ENTER]	Select “m3/h”.	BCD UNIT m3/h
▲ or ▼ [ENTER]	Display “BCD HIGH LIMIT”.	BCD HIGH LIMIT 9999999 m3/h
5 0 0 0 [ENTER]	Enter “5000”.	BCD HIGH LIMIT 5000 m3/h
▲ or ▼ [ENTER]	Display “BCD LOW LIMIT”.	BCD LOW LIMIT 0 m3/h
1 0 [ENTER]	Enter “10”.	BCD LOW LIMIT 10 m3/h
▲ or ▼ [ENTER]	Display “ZERO SUPRESS”.	ZERO SUPRESS OFF
▲ or ▼ [ENTER]	Set “ON”.	ZERO SUPRESS ON
▲ or ▼ [ENTER]	Display “DECIMALPOINT SET”.	DECIMALPOINT SET NO PLACE
▲ or ▼ [ENTER]	Set “2 PLACE”.	DECIMALPOINT SET 2 PLACE
[ESC] [ESC] [ESC]	Move to “Measurement display”.	(Measurement display)

## 5.4 (15) Setting of measurement mode

### Description

The measurement specifications for this flowmeter is determined by selecting the measurement mode.

Measurement mode	Specifications
2-path system (2 paths, 1 pipe)	Measure the flow rate with 2 sets of detectors installed on a pipe
2-pipe system (1 path, 2 pipes)	Measure the flow rate of 2 pipes with a set of detector installed on a pipe.
Single-path system (1 path, 1 pipe)	Measure the flow rate with a set of detector installed on a pipe.

Note) When changing the measurement mode, the flowmeter will be reset .

When changing the measurement mode from 2-pipe to 2-path:		
Operation (example)	Description	Display
<b>FUNC</b> <b>SYSTEM</b>	Move to the "SYSTEM" screen.	UNIT & LANGUAGE SKIP
<b>▲</b> or <b>▼</b> <b>ENTER</b>	Select "MEASUREMENT MODE".	MEASUREMENT MODE 2 PIPES
<b>ENTER</b>	Display is ready to select.	MEASUREMENT MODE 2 PIPES
<b>▲</b> or <b>▼</b> <b>ENTER</b>	Select "2 PATHS".	MEASUREMENT MODE 2 PATHS
<b>ENTER</b>	The flowmeter will be reset and started.	FLH-3 SYSTEM TIME DELTA F
		BACKUP MEMORY LOADING
		Stability Wait! *****
		(Measurement display)

## 5.4 (16) Designation of analog output destination

### Description

Select the definition of the analog output destination (type). The contents of calculation is categorized by selecting the measurement mode.

- The following output can be selected by the measurement mode:

Measurement mode	Single-path output	2-path output	Calculation output			Destination of analog output (selectable)
			Average value	Additional value	Reduction value	
2-path system	○	○	○	—	—	Iout 1 to Iout 3
2-pipe system	○	○	○	○	○	Iout 1 to Iout 3
Single-path system	○	—	—	—	—	Iout 1 , Iout 3

- When setting the measurement mode to 2-path system;

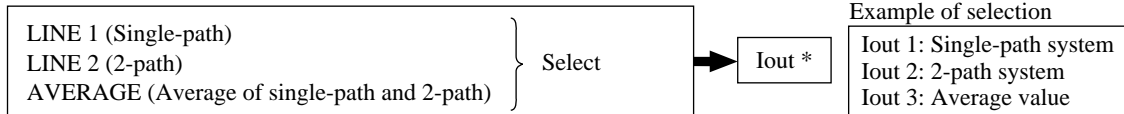

- When setting the measurement mode to 2-pipe system;

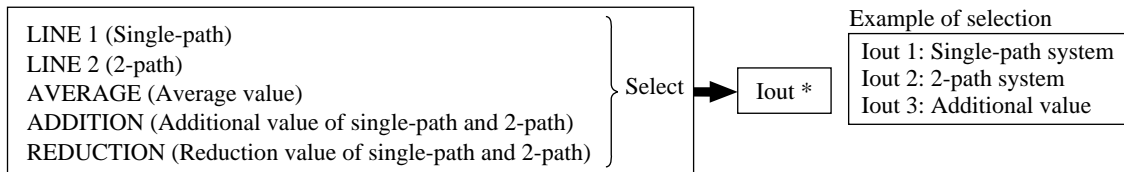

Note) Average value, additional value and reduction value are calculated for the flow rate of each pipe.

- Average value =  $(Q1 + Q2) / 2$
- Additional value =  $(Q1 + Q2)$
- Reduction value =  $(Q1 - Q2)$

- When the measurement mode to single-path system;

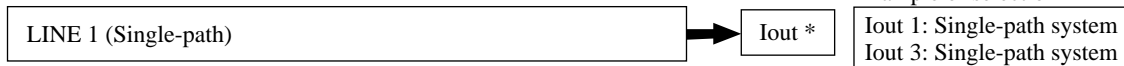

Operation (example)	When providing an output of average values to Iout3 terminals;	Display
<span style="border: 1px solid black; padding: 2px;">FUNC</span> <span style="border: 1px solid black; padding: 2px;">SYSTEM</span>	Move to the "SYSTEM" screen.	UNIT & LANGUAGE SKIP
<span style="border: 1px solid black; padding: 2px;">▲</span> or <span style="border: 1px solid black; padding: 2px;">▼</span> <span style="border: 1px solid black; padding: 2px;">ENTER</span>	Select "AO DEFINITION".	AO DEFINITION Iout 1
<span style="border: 1px solid black; padding: 2px;">ENTER</span>	Display is ready to enter.	AO DEFINITION Iout 1 ■
<span style="border: 1px solid black; padding: 2px;">3</span> <span style="border: 1px solid black; padding: 2px;">ENTER</span>	Enter "3".	AO DEFINITION Iout 3 ■
<span style="border: 1px solid black; padding: 2px;">ENTER</span>	Display is ready to select.	3: AO DEFINITION LINE 1
<span style="border: 1px solid black; padding: 2px;">▲</span> or <span style="border: 1px solid black; padding: 2px;">▼</span> <span style="border: 1px solid black; padding: 2px;">ENTER</span>	Select "AVERAGE".	3: AO DEFINITION AVERAGE
<span style="border: 1px solid black; padding: 2px;">ESC</span> <span style="border: 1px solid black; padding: 2px;">ESC</span> <span style="border: 1px solid black; padding: 2px;">ESC</span>	Move to "Measurement display".	(Measurement display)

## 5.4 (17) Setting of serial communication

### Description

This flowmeter is provided with serial communication ports which are capable of transmitting data to personal computers (See Appendix 4. External Communication Specifications).

Items	Means of input	Range or menu
Communication speed (bps)	Selection	2400, 4800, 9600, 19200bps
Parity	Selection	None, odd, even
Stop bit	Selection	1 bit or 2 bits
Communication method	Selection	RS-232C, RS-485

Operation (example)	Communication speed: 9600 bps, no parity, stop bit of 1 bit Communication means: RS-232C, station No. 01	
Key operation	Description	Display
<b>FUNC</b> <b>SYSTEM</b> <b>▲</b> or <b>▼</b>	Display the "SERIAL COM." screen.	SERIAL COM. SKIP
<b>ENTER</b> <b>▲</b> or <b>▼</b> <b>ENTER</b>	Select "SETTING".	SERIAL COM. SETTING
<b>ENTER</b>	Display "SPEED".	COM. SPEED 9600BPS
<b>▲</b> or <b>▼</b> <b>ENTER</b>	Select "9600BPS".	COM. SPEED 9600BPS
<b>▲</b> or <b>▼</b> <b>ENTER</b>	Display "PARITY".	COM. PARITY NONE
<b>▲</b> or <b>▼</b> <b>ENTER</b>	Select "NONE".	COM. PARITY NONE
<b>▲</b> or <b>▼</b> <b>ENTER</b>	Display "STOP BIT".	COM. STOP BIT 1 BIT
<b>▲</b> or <b>▼</b> <b>ENTER</b>	Select "1 BIT".	COM. STOP BIT 1 BIT
<b>▲</b> or <b>▼</b> <b>ENTER</b>	Display "SERIAL METHOD".	SERIAL METHOD RS232C
<b>▲</b> or <b>▼</b> <b>ENTER</b>	Select "RS232C".	SERIAL METHOD RS232C
<b>▲</b> or <b>▼</b> <b>ENTER</b>	Display "STATION".	STATION No. 01
<b>0</b> <b>1</b> <b>ENTER</b>	Set "01".	STATION No. 01
<b>ESC</b> <b>ESC</b> <b>ESC</b>	Move to "Measurement display".	(Measurement display)

## 6. MAINTENANCE AND INSPECTION

---

### 6.1 Maintenance

#### (1) LCD display unit

Expected service life of LCD is 7 years. It is recommended that LCD should be replaced with new one in about 5 years since it is put into operation, or it may offer deteriorated contrast.

[Replacement procedure]

- ① Power OFF
- ② Remove the connector from the key panel and replace the LCD display unit (see parts list).
- ③ Assembly
- ④ Power ON
- ⑤ Check for normal operation

### 6.2 Inspection

#### (1) Daily check

Confirm the converter is operating normally by using the LCD display unit in accordance with Item “7.1 How to confirm normal operation”.

## 7. TROUBLESHOOTING

### 7.1 How to confirm normal operation

#### 7.1 (1) LCD indication during measurement

Measuring mode	1st line	2nd line
2-path system	Calculation and flow velocity, total value, total pulse and range (%) selected from single-path and 2-path systems are displayed.	The flow rate is displayed.
2-pipe system	Flow velocity, flow rate, total value, total pulse and range (%) selected from single-path system are displayed.	Flow velocity, flow rate, total value, total pulse and range (%) selected from 2-path system are displayed.
Single-path system	Flow velocity, total value, total pulse and range (%) are displayed.	Flow rate is displayed.

#### 7.1 (2) Contents displayed on LCD

1st line	①②③④⑤⑥⑦⑧⑨⑩⑪⑫⑬⑭⑮⑯
2nd line	①②③④⑤⑥⑦⑧⑨⑩⑪⑫⑬⑭⑮⑯

Digit	Contents
①	Measuring condition (flicker) * : Normal operation ← : Over display digit C : Low-flow cut E : Range over B : Backup error U : Transmission error between modules F : Receiving waveform error
②	Flow direction : Forward direction - : Reverse direction
③ to ⑨	Data display
⑩	Blank
⑪ to ⑯	Units

### 7.1 (3) Check of information on measuring conditions

The information on RAS, status and data under the measuring conditions can be checked;

#### ① RAS information

When observing details of error conditions.

When an error occurs, "1" is displayed on LCD.

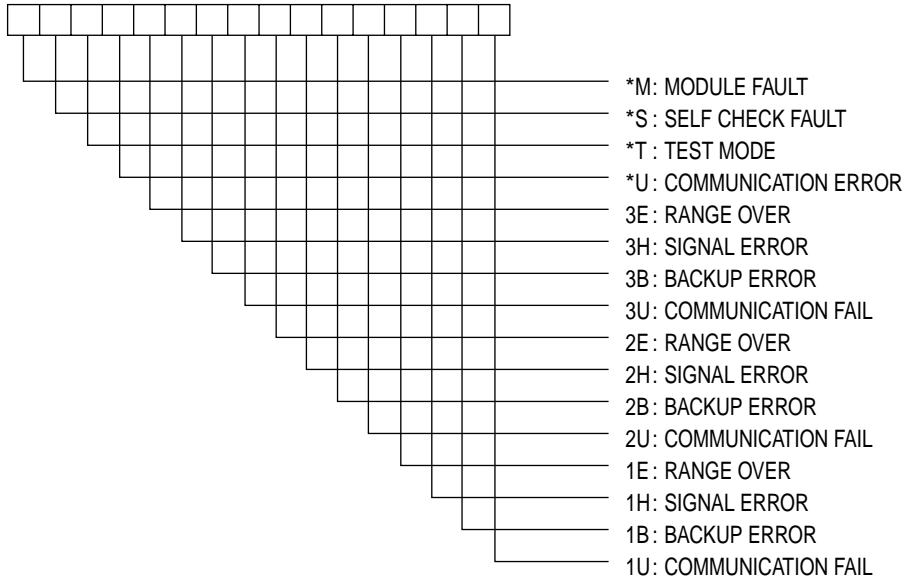

- \*1) \*M to \*U : RAS information on this flowmeter system
- 3E to 3U : RAS information on data 3
- 2E to 2U : RAS information on data 2
- 1E to 1U : RAS information on data 1

#### ② Status information

When observing the setting status and integrating status;

When an error occurs, "1" is displayed on LCD.

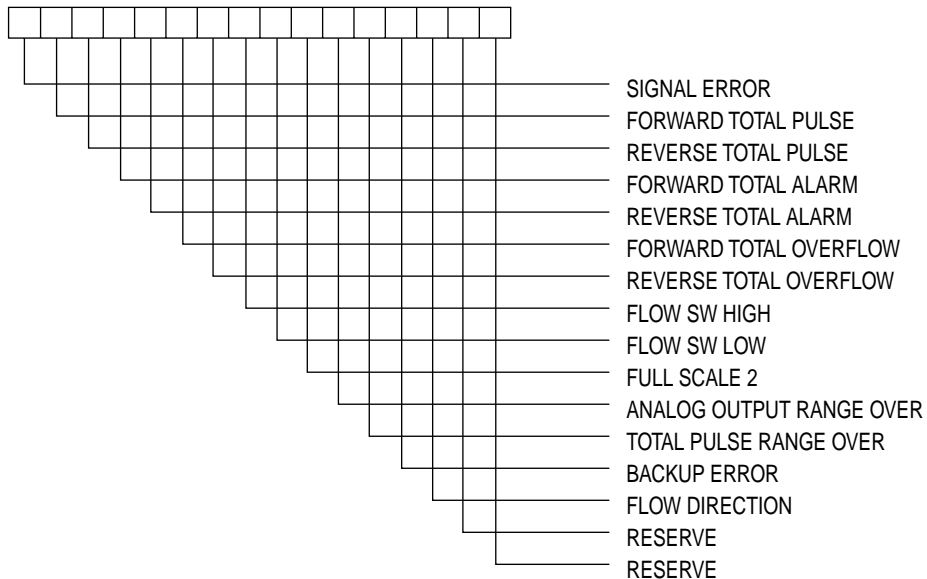

#### ③ Information on measuring data

The data information including the propagation time, the time difference, and so on can be checked.



Operation (example)	When checking the information of data 3 on the status or when checking the RAS information:	
Key operation	Description	Display
<div style="display: inline-block; border: 1px solid black; padding: 2px;">FUNC</div> <div style="display: inline-block; border: 1px solid black; padding: 2px; margin-left: 10px;">CHECK</div>	Move to the “CHECK” screen.	<div style="border: 1px solid black; padding: 5px;">           INFORMATION  <div style="text-align: right;">RAS</div> </div>
<div style="display: inline-block; border: 1px solid black; padding: 2px;">ENTER</div>	The screen is ready for selection.	<div style="border: 1px solid black; padding: 5px;">           INFORMATION  <div style="text-align: right;"><u>RAS</u></div> </div>
<div style="display: inline-block; border: 1px solid black; padding: 2px;">▲</div> or <div style="display: inline-block; border: 1px solid black; padding: 2px;">▼</div> <div style="display: inline-block; border: 1px solid black; padding: 2px; margin-left: 10px;">ENTER</div>	Select “STATUS”.	<div style="border: 1px solid black; padding: 5px;">           INFORMATION  <div style="text-align: right;">STATUS</div> </div>
<div style="display: inline-block; border: 1px solid black; padding: 2px;">ENTER</div>	The screen is ready for entry.	<div style="border: 1px solid black; padding: 5px;">           STATUS INF.  <div style="text-align: right;">SELECT No. 1 ■</div> </div>
<div style="display: inline-block; border: 1px solid black; padding: 2px;">3</div> <div style="display: inline-block; border: 1px solid black; padding: 2px; margin-left: 10px;">ENTER</div>	Enter “3”.	<div style="border: 1px solid black; padding: 5px;">           STATUS INF.  <div style="text-align: right;">SELECT No. 3</div> </div>
<div style="display: inline-block; border: 1px solid black; padding: 2px;">◀</div> or <div style="display: inline-block; border: 1px solid black; padding: 2px;">▶</div>	Move the cursor to a point where the bit is set.	<div style="border: 1px solid black; padding: 5px;">           3 : STATUS INF.            0001000000000000         </div>
<div style="display: inline-block; border: 1px solid black; padding: 2px;">ENTER</div>	Display the information.	<div style="border: 1px solid black; padding: 5px;">           3 d : FORWARD TOTAL            ALARM         </div>
<div style="display: inline-block; border: 1px solid black; padding: 2px;">ESC</div> <div style="display: inline-block; border: 1px solid black; padding: 2px; margin-left: 10px;">ESC</div> <div style="display: inline-block; border: 1px solid black; padding: 2px; margin-left: 10px;">ESC</div> <div style="display: inline-block; border: 1px solid black; padding: 2px; margin-left: 10px;">ENTER</div>	The screen is ready for selection.	<div style="border: 1px solid black; padding: 5px;">           INFORMATION  <div style="text-align: right;"><u>STATUS</u></div> </div>
<div style="display: inline-block; border: 1px solid black; padding: 2px;">▲</div> or <div style="display: inline-block; border: 1px solid black; padding: 2px;">▼</div> <div style="display: inline-block; border: 1px solid black; padding: 2px; margin-left: 10px;">ENTER</div>	Select “RAS”.	<div style="border: 1px solid black; padding: 5px;">           INFORMATION  <div style="text-align: right;">RAS</div> </div>
<div style="display: inline-block; border: 1px solid black; padding: 2px;">◀</div> or <div style="display: inline-block; border: 1px solid black; padding: 2px;">▶</div>	Move the cursor to a point where the bit is set.	<div style="border: 1px solid black; padding: 5px;">           RAS INF.            0000100000000000         </div>
<div style="display: inline-block; border: 1px solid black; padding: 2px;">ENTER</div>	Display the information.	<div style="border: 1px solid black; padding: 5px;">           3 E : RANGE OVER         </div>
<div style="display: inline-block; border: 1px solid black; padding: 2px;">ENTER</div>	Display the contents.	<div style="border: 1px solid black; padding: 5px;">           OUTPUT RANGE  <div style="text-align: right;">&lt; UP or DOWN &gt;</div> </div>
<div style="display: inline-block; border: 1px solid black; padding: 2px;">▲</div> or <div style="display: inline-block; border: 1px solid black; padding: 2px;">▼</div>	If the UP or DOWN key blinks, press	<div style="border: 1px solid black; padding: 5px;">           TOTAL RATE  <div style="text-align: right;">&lt; UP or DOWN &gt;</div> </div>
<div style="display: inline-block; border: 1px solid black; padding: 2px;">▲</div> or <div style="display: inline-block; border: 1px solid black; padding: 2px;">▼</div> key.		
<div style="display: inline-block; border: 1px solid black; padding: 2px;">ESC</div> <div style="display: inline-block; border: 1px solid black; padding: 2px; margin-left: 10px;">ESC</div> <div style="display: inline-block; border: 1px solid black; padding: 2px; margin-left: 10px;">ESC</div>	Move to Measurement display.	<div style="border: 1px solid black; padding: 5px;">           (Measurement display)         </div>



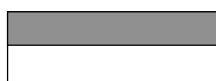

#### 7.1 (4) LCD indication when power turned ON

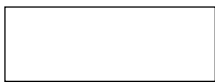
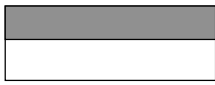

In case of no indication  
 System abnormal (CPU stopped)  
 └ Contact Badger Meter.

## 7.2 Faults and remedies

### 7.2 (1) LCD display abnormal

Status	Cause
 No indication appears.	<ul style="list-style-type: none"> <li>• Power is not turned ON.</li> <li>• Power voltage is low.</li> <li>• Fuse is burnout.</li> <li>• LCD is abnormal. ➡ <span style="border: 1px solid black; padding: 2px;">Take remedy in “7.2 (5) Remedy for hardware fault”</span></li> <li>• DC power supply polarity is connected reversely.</li> </ul>
 Dark indication on upper side.	<ul style="list-style-type: none"> <li>• Power voltage is low.</li> <li>• LCD is abnormal. ➡ <span style="border: 1px solid black; padding: 2px;">Take remedy in “7.2 (5) Remedy for hardware fault”</span></li> <li>• DC power supply polarity is connected reversely.</li> </ul>
 Random indication	<ul style="list-style-type: none"> <li>• Hardware fault. ➡ <span style="border: 1px solid black; padding: 2px;">Take remedy in “7.2 (5) Remedy for hardware fault”</span></li> </ul>
 Unclear display	<ul style="list-style-type: none"> <li>• Ambient temperature low. (less than <math>-10^{\circ}\text{C}</math>) ➡ Increase the temperature.</li> <li>• LCD indicator is worn out. ➡ Replace the LCD.</li> </ul>
 Whole is dark	<ul style="list-style-type: none"> <li>• Ambient temperature is high. (<math>60^{\circ}\text{C}</math> or more) ➡ Decrease the temperature.</li> </ul>

### 7.2 (2) Key abnormal

Status	Cause
No response at press of input key Specific keys can not be operated. Key operation is different from that defined.	<ul style="list-style-type: none"> <li>• Hardware fault. ➡ <span style="border: 1px solid black; padding: 2px;">Take remedy in “7.2 (5) Remedy for hardware fault”</span></li> </ul>

7.2 (3) Measured value abnormal

Status	Cause	Remedy
Minus (-) symbol indicated on measured value	<ul style="list-style-type: none"> <li>• Connection between transmitter and sensor is reversed. (Upstream and down stream detectors should be connected reversely)</li> </ul>	<p>➔ Connect correctly.</p>
Measured value fluctuates though flow rate is constant.	<ul style="list-style-type: none"> <li>• Flow of fluid is reversed.</li> <li>• Straight pipe length is inadequate. ➔</li> <li>• Pump, valve etc. which disturbs flow is located nearby. ➔</li> <li>• There is pulsation in the flow ➔</li> </ul>	<p>Move instrument to a place where 10D can be maintained on upstream and 5D on downstream.</p> <p>➔ Attach instrument at least 30D away</p> <p>➔ Set the damping to increase the response time.</p>
Measured value is not changed with change in flow rate.	<p>Ultrasonic wave is not transmitted inside pipe but measured value remains unchanged (HOLD).</p> <p>① Installation is improper</p> <div style="border: 1px solid black; padding: 5px; margin-bottom: 10px;"> <ul style="list-style-type: none"> <li>• Error in piping specifications</li> <li>• Sensor attached to welded part</li> <li>• Error in sensor mounting dimensions</li> <li>• Error in silicon appliance at the time of mounting the sensor</li> <li>• Error in connection of the sensor cable.</li> </ul> </div> <p>➔</p> <p>② Problem with piping, fluid</p> <p>⊙ Pipe not filled with fluid ➔</p> <p>⊙ Bubbles included in the fluid</p> <div style="border: 1px solid black; padding: 5px; margin-bottom: 10px;"> <p>If measured value becomes normal when flow has stopped, it indicates that bubbles are contained in the fluid.</p> </div> <div style="border: 1px solid black; padding: 5px;"> <p>When the sensor is mounted right after the valve, cavitation may occur in the pipe, resulting in entry of air bubbles.</p> </div> <p>(Continued)</p>	<div style="border: 1px solid black; padding: 5px; margin-bottom: 10px;"> <p>After confirming the cause, remove the sensor and apply sufficient amount of silicone to the sensor. Then, mount the sensor again at a position slightly away from previous position.</p> </div> <div style="border: 1px solid black; padding: 5px; margin-bottom: 10px;"> <p>Fluid out a pipe filled with fluid on the same pipeline, and relocate the sensor to the pipe.</p> <ul style="list-style-type: none"> <li>• Attach the sensor to the lowest place on the pipeline.</li> </ul> </div> <div style="border: 1px solid black; padding: 5px;"> <p>Eliminate the bubbles.</p> <ul style="list-style-type: none"> <li>• Raise the level of the pump well.</li> <li>• Check the shaft seal of the pump.</li> <li>• Retighten the flange of negative pressure pipe.</li> <li>• Arrange so that fluid doesn't fall into the pump well</li> </ul> <p>Move the sensor to a place where no bubbles are contained.</p> <ul style="list-style-type: none"> <li>• Pump inlet side</li> <li>• Upstream side of valve</li> </ul> </div>

Status	Cause	Remedy
(Continued)	<p>◎ Turbidity is high.</p> <p>┌ Turbidity is higher than inflow water contamination or return sludge. ┐</p> <p>◎ Scale deposits on the inside of old pipe</p> <p>◎ Thick lining</p> <p>┌ Mortar lining is several ten millimeters thick ┐</p> <p>◎ Separation of lining</p> <p>┌ This is gap between lining and pipe. ┐</p> <p>◎ Sensor is mounted on bent or tapered pipe.</p> <p>③ Effect of external noise</p> <p>┌ • There is a radio broadcast station nearby. ┐</p> <p>┌ • Measurement conducted near a passage of vehicles or electric cars. ┐</p> <p>• Mounting of sensor is improper.</p> <p>• Mounting dimensions</p> <p>• Sensor is separated from pipe</p> <p>④ Hardware fault</p>	<p>• Change sensor mounting from V method to Z method.</p> <p>• Move sensor to a place of smaller diameter on the same pipeline.</p> <p>• Relocate sensor to another place or pipe line.</p> <p>Mount sensor on a straight pipe.</p> <p>• Keep the cable between converter and sensor as short as possible.</p> <p>• Ground the converter and piping.</p> <p>• Mount sensor parallel with pipe at the correct position.</p> <p>• Press sensor so it is securely mounted on the pipe.</p> <p>Refer to Item “7.2(5) Remedy for hardware fault”.</p>
Measured value not zero when fluid stops flowing.	<p>• Fluid forms a convection inside the pipe.</p> <p>• Zero point adjustment</p> <p>• Pipe is not full of water or it is empty of water when water stops flowing.</p>	<p>This is normal.</p> <p>• Readjust the zero point after fluid has stopped flowing.</p> <p>This is normal.</p> <p>• The value may vary at Item “5.4(4) Setting of output at abnormal measurement”.</p>

Status	Cause	Remedy
<p>Error in measured value</p>	<ul style="list-style-type: none"> <li>• Input piping specifications differ from the actual ones.</li> <li>• Scale deposits on old pipe</li> </ul>	<p>➔ Error of about 3% occurs when inner diameter differs by 1%.</p> <ul style="list-style-type: none"> <li>• Input the correct specifications</li> <li>• Input scale as a lining.</li> </ul>
	<ul style="list-style-type: none"> <li>• Length of straight pipe is inadequate. (should be at least 10D upstream and 5D downstream.)</li> </ul>	<p>➔ Change the sensor to another mounting position (upstream of disturbing objects)</p> <p>No disturbing objects in flow within 30D upstream without pump, valve, combined pipe, etc.</p> <ul style="list-style-type: none"> <li>• Try mounting the sensor at various angles versus the pipe section, and mount it where average value is obtained.</li> </ul>
	<ul style="list-style-type: none"> <li>• Pipe is not filled with fluid or sludge is deposited in the pipe.</li> </ul>	<p>➔ Occurs particularly where sectional area is small.</p> <ul style="list-style-type: none"> <li>• Move sensor to a vertical pipe.</li> </ul>

## 7.2 (4) Analog output abnormal

Status	Cause	Remedy
Current output is not matched though indication value is not 0.	Range setting is not performed.	➔ • Set.
Output is 0mA.	Cable is disconnected.	
Output is below 4mA when indication is 0.	Zero adjustment of analog output has deviated.	➔ Adjust the analog output.
Output is greater than 20mA.	E is displayed on LCD indicator. (Note)	➔ Range over: • Reset analog output range data.
	Span adjustment is incorrect.	➔ • Adjust the analog output.
Indication is changed but analog output remains the same.	Output load is greater than 1kΩ.	➔ • Reduce the load to 1kΩ or less.
Indication does not agree with analog output.	Zero or span of analog output has deviated.	➔ Adjust the analog output.
Analog output doesn't change even after it has been adjusted.	Hardware fault	➔ Contact Badger Meter.

Note: When the base scale is not set to 0 within the range of an analog output, the flow display may not be matched with the analog output.

## 7.2 (5) Remedy for hardware fault

When hardware is in trouble after following “6. Maintenance and inspection” and “7. Troubleshooting”, details of trouble and self-check should be notified to Badger Meter.

## 8. MOUNTING METHOD

---

### 8.1 Mounting of sensor

#### 8.1 (1) Mounting procedure of sensor

Mount the sensor on the pipe, and perform the following works in order before making measurement.

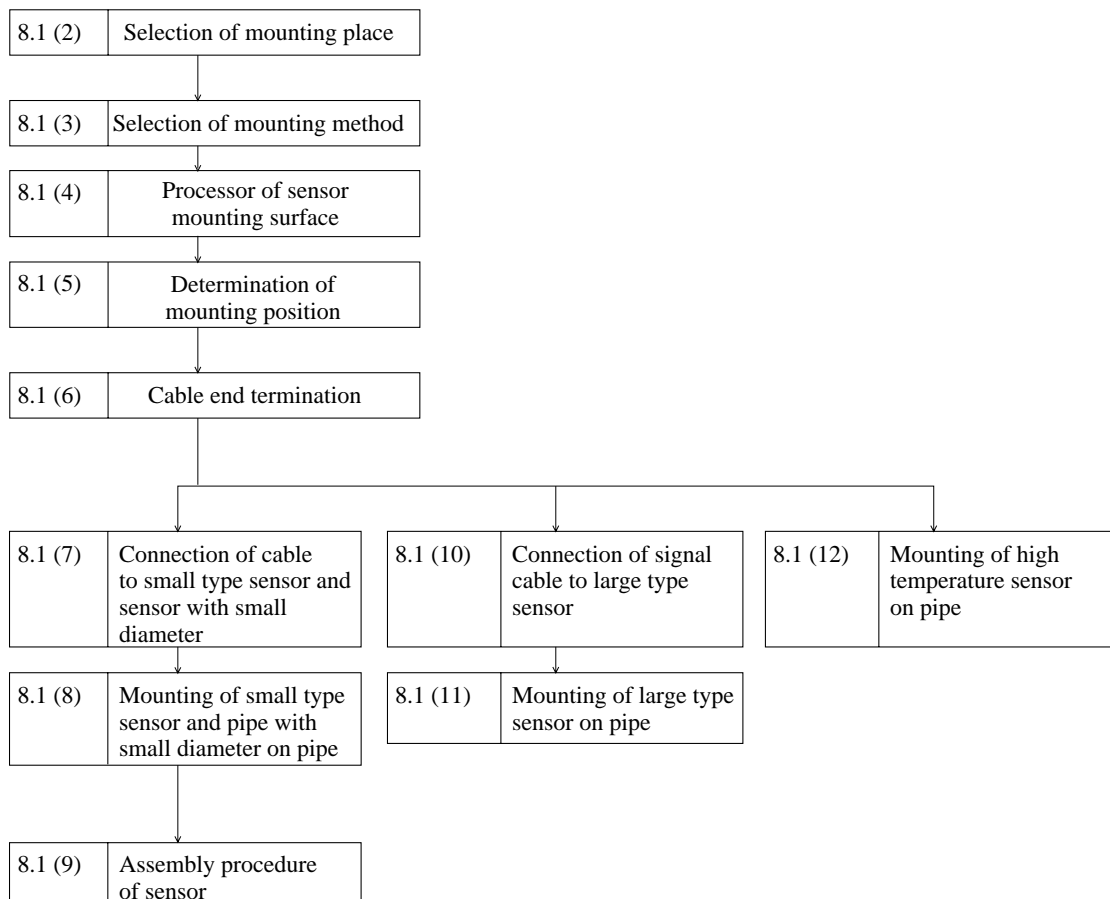

## 8.1 (2) Selection of mounting place

Mounting place for the sensor, i. e. conditions of piping where flow rate is measured, has considerable influence on measurement accuracy.

A place satisfying the following conditions should be selected.

- ① A place where there is a straight pipe portion of 10D or more on upstream side and of 5D or more on the downstream side.
- ② A place where there are no factors which disturb the flow (pumps, valves, etc.) within 30D on upstream side.
- ③ Pipe must be filled up with fluid. No bubbles should be contained.
- ④ Make sure that a maintenance space is provided around the piping where the sensor is mounted. (See Fig. 8-1.)

Note) A space should be provided so that maintenance work can be made with workers standing on both sides of the piping.

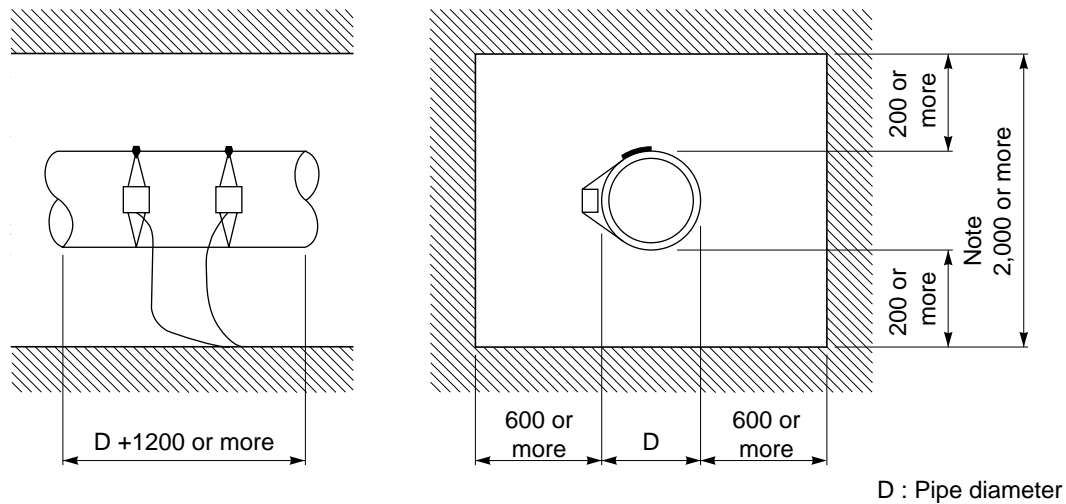
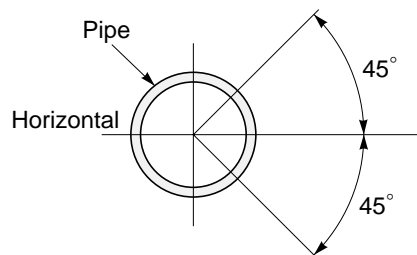

Fig.8-1 Space required for mounting sensor

### ⚠ CAUTION

- ① Where a horizontal pipe is used, install the sensor within  $\pm 45^\circ$  from the horizontal plane. Where a vertical pipe is used, the sensor can be installed anywhere.



- ② Avoid installing the sensor on a deformed portion of pipe or welded portion of pipe, or on flange.

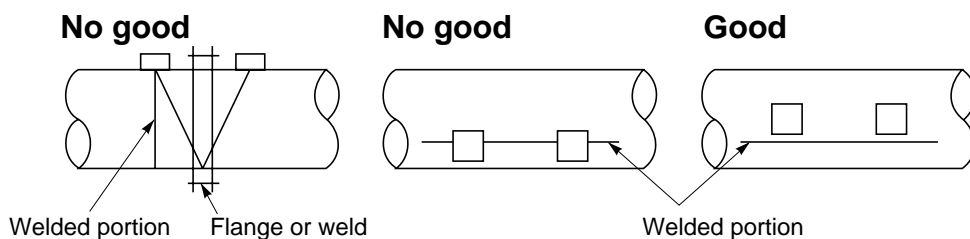



### 8.1 (3) Selection of mounting method

There are two ways for mounting the sensor, the V method and the Z method (See Fig. 8-2).

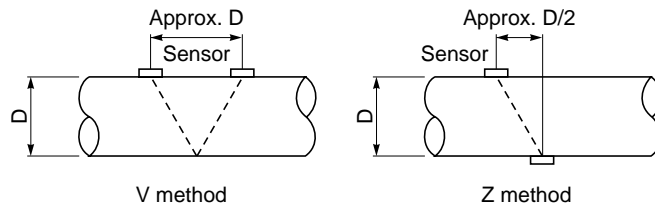

Fig. 8-2 Mounting method

The Z method should be used in the following cases.

- Where a mounting space is not available. (As shown in the figure above, the mounting dimension with the Z method is about half of that with the V method).
- When measuring fluid of high turbidity such as sewage.
- When the pipe has a mortar lining.
- When the pipe is old and has a thick accumulation of scale on its inner wall.

#### Selection standard

- For a large size sensor with inside diameter of more than 300 mm, the Z method is recommended for mounting.
- For aging pipes, cast iron pipes or pipes with mortar lining that will interrupt the propagation of ultrasonic signals, Model FLW11 or FLW50 is recommended, where applicable.

#### Sensor

Small type sensor Type : FLW1	Z method	
	V method	
Large type sensor Type : FLW5	Z method	
	V method	
High temperature sensor FLW32		

13 25 50 100 200 300 400 1000 3000 6000

: Range noted in specifications  
 : Range specified with piping material (FRP, PVC or other plastic materials)

→ Inside diameter (mm)

### 8.1 (4) Processing of sensor mounting surface

Using thinner and/or sandpaper, remove pitch, rust and unevenness over a width of (L) + 200mm on the pipe circumference where the sensor is mounted.

Note) If there is a jute winding on the pipe circumference, remove it and carry out the above processing.

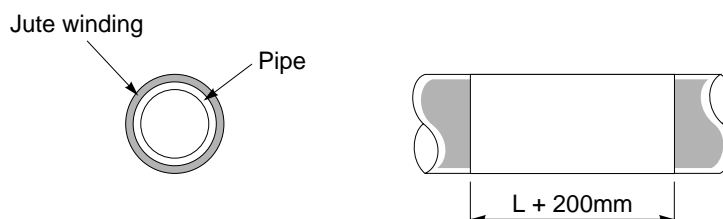

## 8.1 (5) Determination of mounting position (with Z method for large and small types)

Carry out the following to determine the mounting position.

Gauge paper is necessary for this work. (Refer to Appendix 1. "How to make gauge paper".)

- Align the edge of gauge paper with a point about 100mm from one end of the processed section, and wrap the paper around the pipe so that the line drawn on the paper is parallel with the pipe shaft. (The paper should be taped to prevent slipping.) At this time, make sure that the paper edge is even.

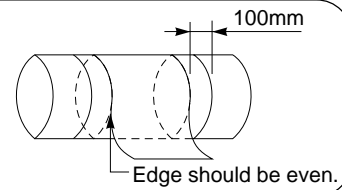

- Extended the line drawn on the paper and mark a straight line A on the pipe.

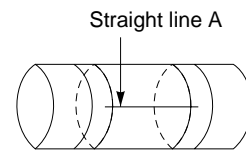

- Mark a line along on edge of the paper. Assume the intersection of the line and the straight line A is  $A_0$ .

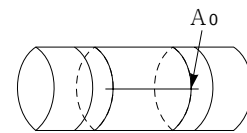

V method

Z method

Example)  $L = 200\text{mm}$

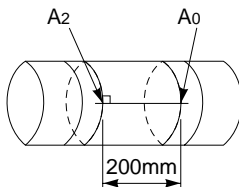

- Remove the gauge paper and measure the mounting dimension from  $A_0$ . Then, draw a line which crosses the straight line A (determine the position  $A_2$ ).

$A_0$  and  $A_2$  are the mounting position.

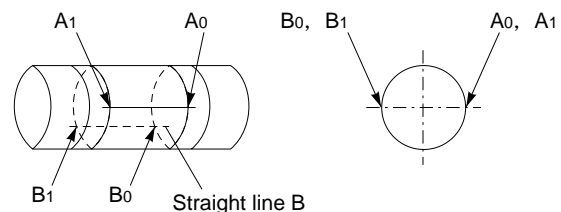

- Measure the circumference of the pipe from the point  $A_0$ , and mark a line (straight line B) between the point  $B_0$  and  $B_1$  obtained at  $1/2$  of the circumference.

Example)  $L = 100\text{mm}$

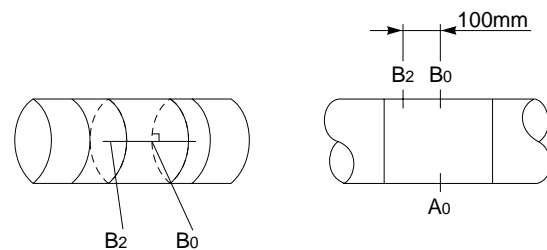

- Put a mark at point  $B_0$  and remove the gauge paper. Measure the mounting dimension from  $B_0$  and mark a line crossing the straight line B (determine the position  $B_2$ ). In this way, the mounting position is determined.  $A_0$  and  $B_2$  are the mounting position.

---

### 8.1 (6) Cable end treatment

The end of coaxial cable is treated at the factory prior to delivery. If the cable needs to be cut before use, the conductor and the shielding wires should be treated using clamp terminals.

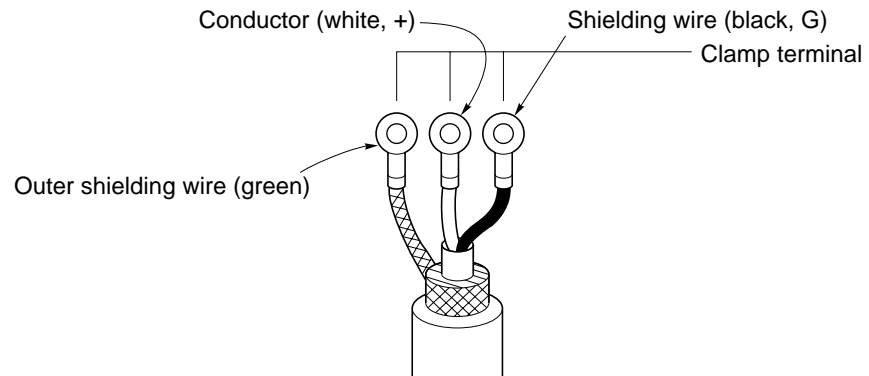

Note: When cutting the coaxial cable, make sure that the upstream side and the downstream side are the same in length.

## 8.1 (7) Connection of cable to small type sensor

- ① Loosen the earth screw and the retaining knob on the sensor using a screwdriver, then remove the cover from the sensor.

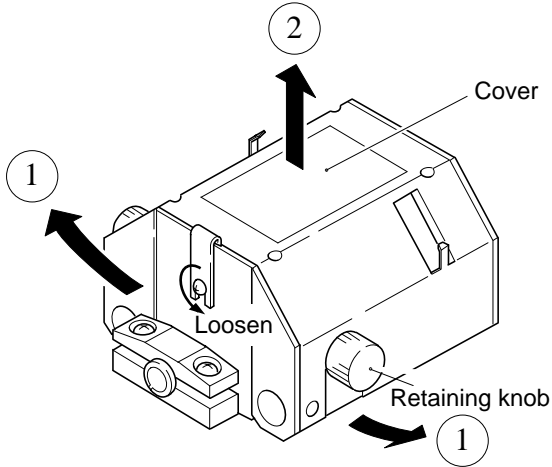

- ④ Secure the coaxial cable with the cable clamp.

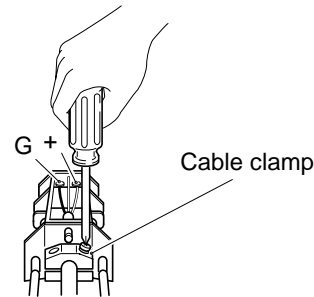

- ② Select a mounting position on the pipe.

Note) Mount the sensors so that the upstream and downstream sensors can be distinguished with each other.  
Remove the cable clamp and insert the coaxial cable through the cable lead-in port.

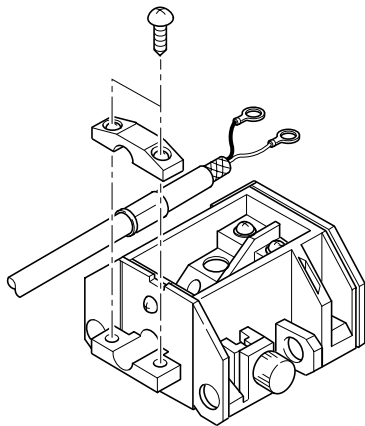

- ⑤ Remove foreign matters from the terminals, and mold the while terminal block with silicone filler.
- Cut off the tip of the silicone filler tube. Apply silicone to the terminal block while pressing the head of the tube against the bottom of terminals.  
At this time, care should be taken to prevent entry of air bubbles.

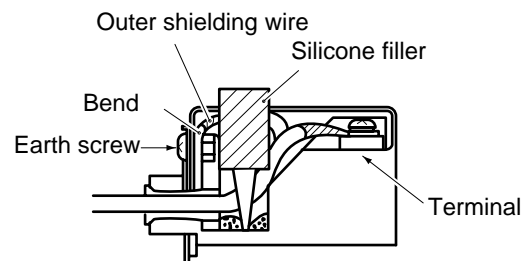

- ③ Connect the cable to the terminal (G, +) and the earth screw.

Note) After connecting the outer shielding wire to the earth screw, be sure to bend the amplifier terminal.

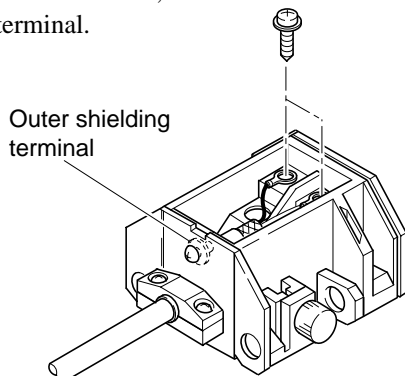

- ⑥ Put the cover on the sensor.

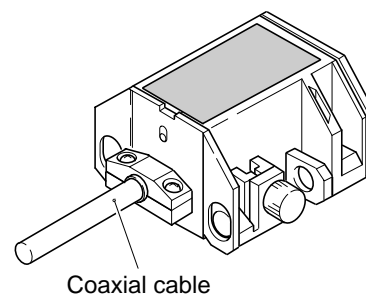

## 8.1 (8) Mounting of small type sensor on pipe

The small type sensor is mounted on pipe with a diameter of  $\phi 50$  to 250 (V method) or  $\phi 150$  to 400 (Z method) for measurements.

### ① Mounting of sensor (V method) Mounting the sensor using the following procedure. For mounting, prepare a scale or a slide calipers.

- ① Loosen the retaining knob A (4 places), slide the sensor so as to match the mounting dimension, place a scale on the mounting dimension reference surface C and adjust the dimension, then tighten the retaining knob A.

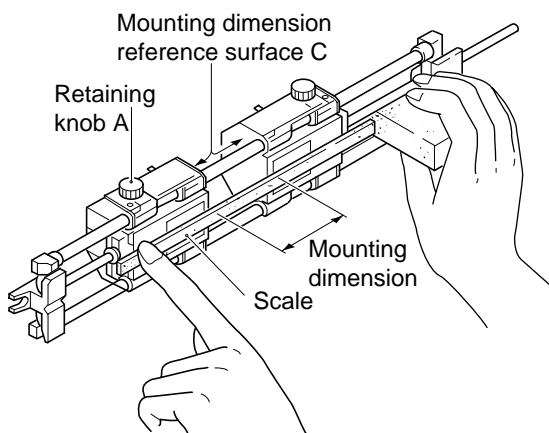

- ③ Raise the end of the pipe fitted with the sensor, and attach the yellow ring on the chain to the hook.

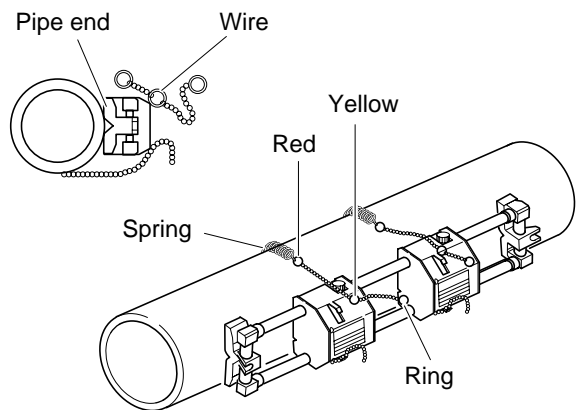

Attach the other chain to the other hook of sensor, and secure it loosely.

- ② Spread silicone filler over the whole transmitting side of the sensor. Care should be taken to prevent entry of air bubbles.

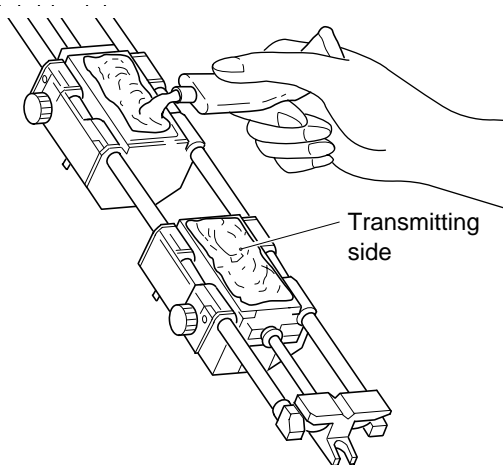

Clean the surface of the pipe and mount the sensor.

- ④ Pull the red ring and attach it to the hook.  
Use the same procedure for the other sensor.

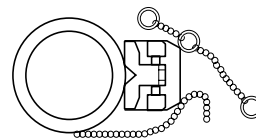

Turn over the frame end so that the sensor makes a close contact with the pipe.

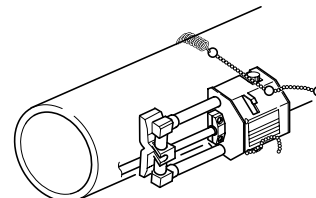

Press the sensor firmly against the pipe.  
Ensure that the sensor makes a close contact with the pipe.

## ② Mounting of sensor (Z method)

### Mounting the sensor using the following procedure

- ① Spread silicone filler over the whole transmitting side of the sensor. Care should be taken to prevent entry of air bubbles.

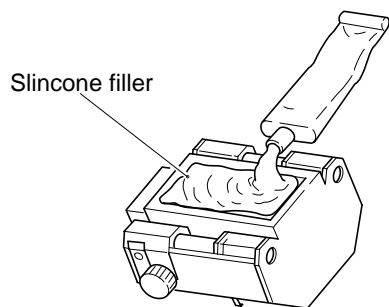

Clean the surface of the pipe, then mount the sensor.

- ③ Make sure that the center mark on the sensor is aligned with the marking line. Then, connect the coaxial cable to the transmitter.

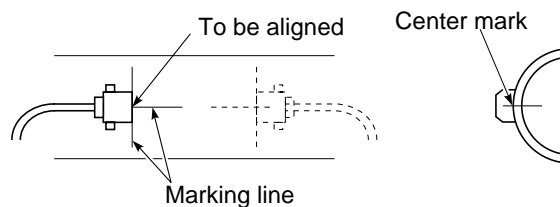

Note) Do not pull the coaxial cable. If it is pulled, the sensor is shifted which results in incorrect measurements due to poor contact with the pipe.

- ② Press the sensor against the pipe. Align the center of the sensor with the intersection of the marking line, and the mounting dimension reference surface with the marking line.

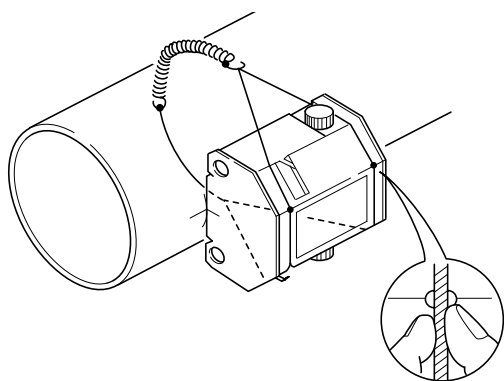

## 8.1 (9) Assembling procedure of the sensor

When the small type sensor (FLW1) is shipped with cables of more than 10m in length, it is delivered, disassembled since cable weight is applied to the stand or piping of the sensor during shipment.

Follow the procedure given below.

### Assemble of parts

- ① Be sure to read the “Cautions” before assembling the parts.

Insert the frame end onto one side of 2 pipes.

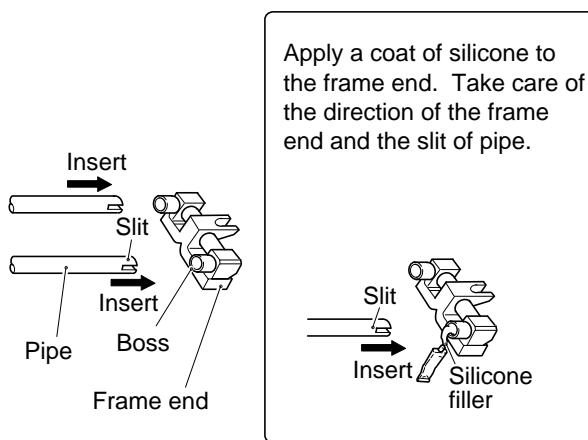

After inserting the pipes, tap the frame end with a plastic hammer or the like.

- ③ Insert another sensor onto the pipes.  
Insert it in the correct direction.

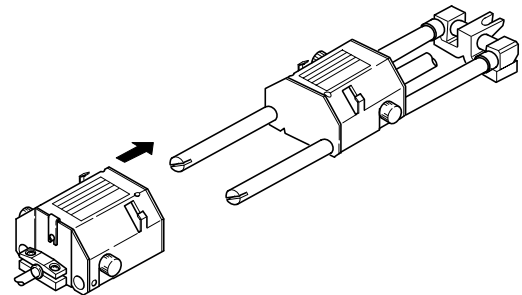

- ② Loosen the tightening knob on the sensor and insert the pipes.

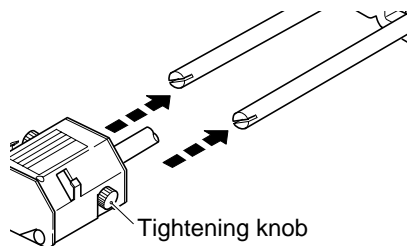

The sensor should be inserted in the correct direction.

- ④ Insert the frame end onto the other side of pipes.  
Assembling method is the same as ①

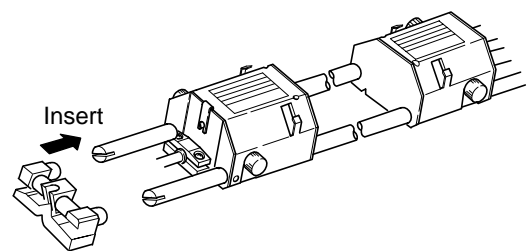

**Note:** After assembling the sensor, leave it at room temperature for a day to harden the filler (to obtain the required assembling strength).

## 8.1 (10) Connection of cable to large type sensor

- ① Slightly move the sensor cover and remove it using a screwdriver or the like.

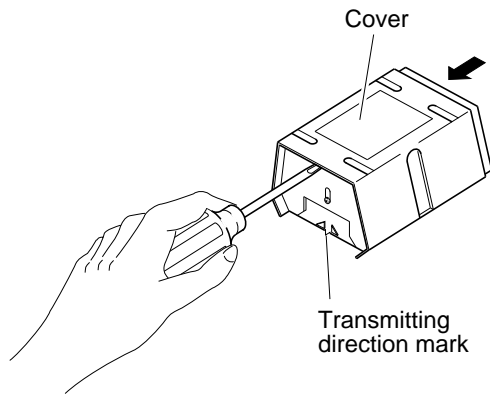

- ③ Connect the coaxial cable to the terminals (G, +) and secure the cable with the cable clamp.

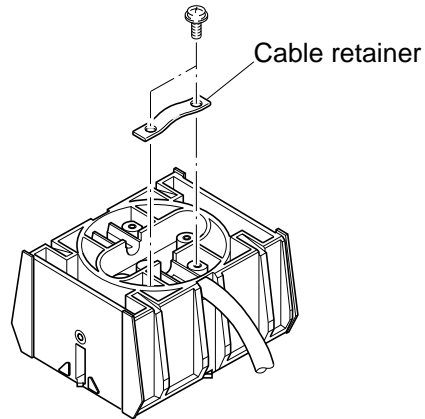

- ② Confirm the mounting position on the pipe.
- Align the transmitting direction marks so that they are facing with each other.

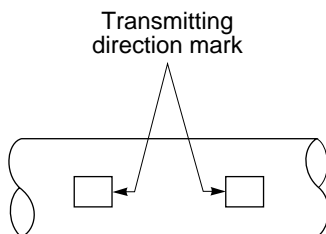

- ④ Remove foreign objects from the terminal section, and mold the whole terminal section with silicone filler.
- Cut the tip of the silicone filler tube. Apply silicone while pressing the head of the tube against the bottom of the terminal section. Be careful not to let babbles form.

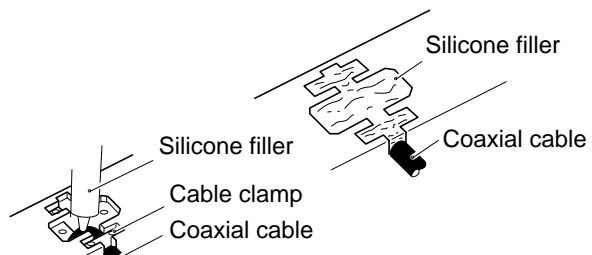



## 8.1 (11) Mounting of large type sensor on pipe

### ① Adjustment of guide plate height

Attach the sensor to the pipe. Make sure that it is parallel with the pipe shaft.

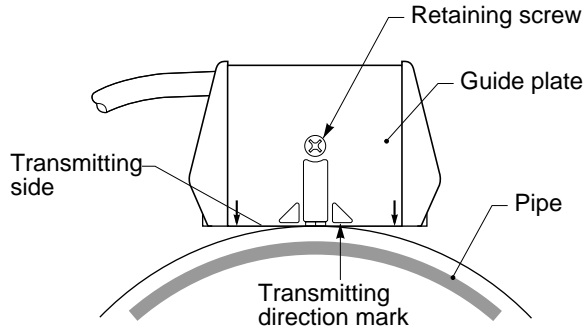

Loosen the guide plate retaining screw, and slide the plate until its edge and the transmitting side are in contact with the pipe surface. Tighten the retaining screw.

### ② Setting of wire rope length

Place the sensor on the marking line and attach the wire rope and mounting spring.

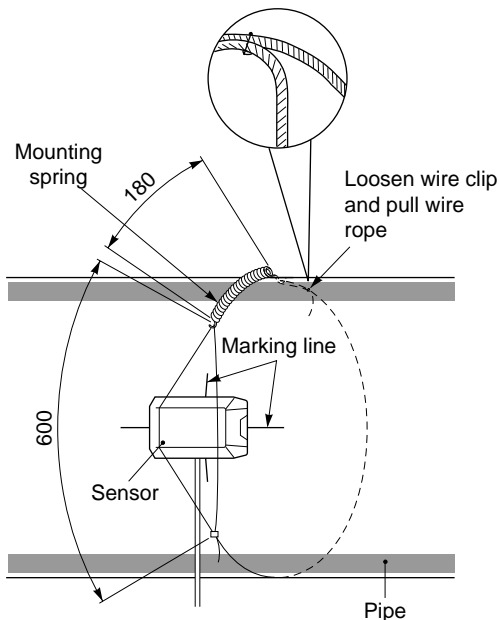

Loosen the wire clip, stretch the wire rope until the overall length of the mounting spring becomes 180mm, and secure the wire clip (free length of the mounting spring is 110mm). Remove the sensor with the wire rope fixed in place.

### ③ Mounting of sensor

- Clean the sensor transmitting surface and pipe mounting surface.
- Spread silicone filler over the whole transmitting surface of the sensor.
- The thickness of silicone filler should be about 3mm.

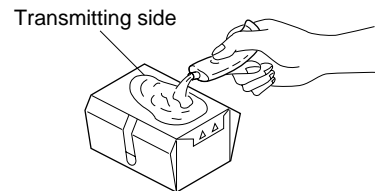

- Spread the wire rope near the marking line to right and left. Attach the sensor firmly to the pipe and hook the wire rope.

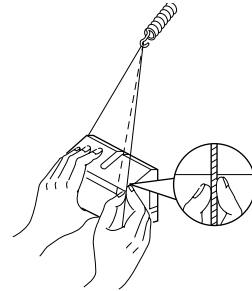

- Make sure that the matching mark on the sensor is aligned with the marking line. Also, make sure the transmitting direction marks on the sensor are facing with each other.

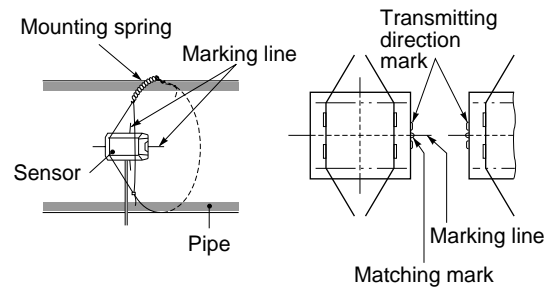

- Confirm that the sensor matching mark is aligned with the marking line, then connect the coaxial cable to sensor.

Note) Do not pull the coaxial cable. If it is pulled, the sensor may move from its mounting position which affects correct measurements.

## 8.1 (12) Mounting of high temperature sensor on pipe

- ① By loosening lock nuts, slide the sensor to fit the mounting size displayed on the converter. Tighten the lock nuts.

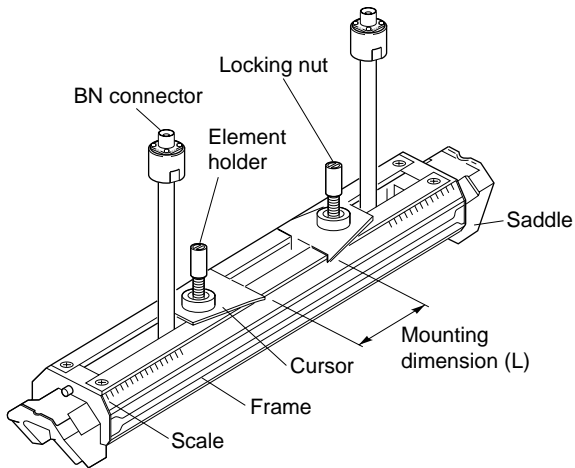

- ③ Mount the sensor saddles on the pipe with stainless belt.

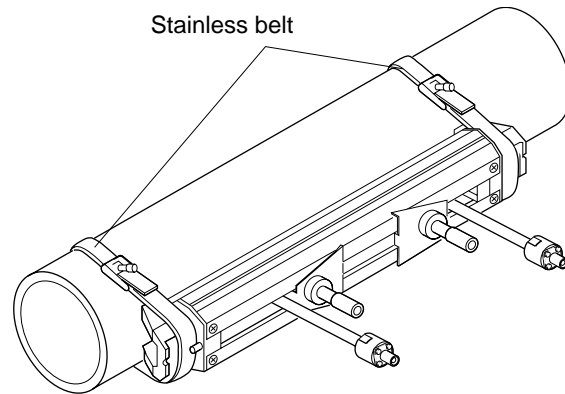

- ② Spread high-temperature grease over the whole transmitting surface of the sensor.

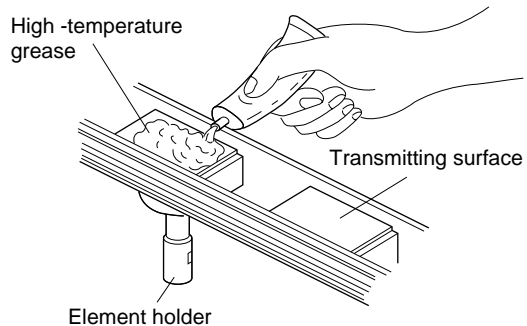

Turn the element holder counterclockwise to return the sensor. Clean the surface of the pipe and mount the sensor on the pipe.

- ④ Check that the sensor is properly attached in parallel to the pipe and it is mounted according to the mounting dimension. Then, turn the element holder clockwise, so that the sensor makes a close contact with the pipe.

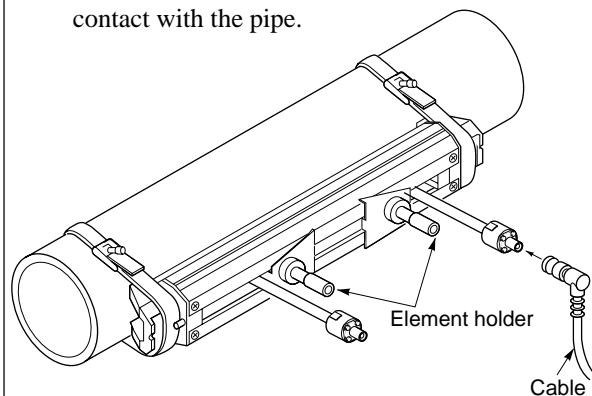

Stop turning the element holder where the transmitting surface contact the surface of pipe, and thus the element holder won't rotate. Don't turn it excessively.

# APPENDIX 1. HOW TO MAKE GAUGE PAPER

---

- ① Prepare a rectangular sheet of paper (or vinyl sheet) with its length of more than  $4D$  and width of  $200\text{mm}$  ( $D$ , if possible).

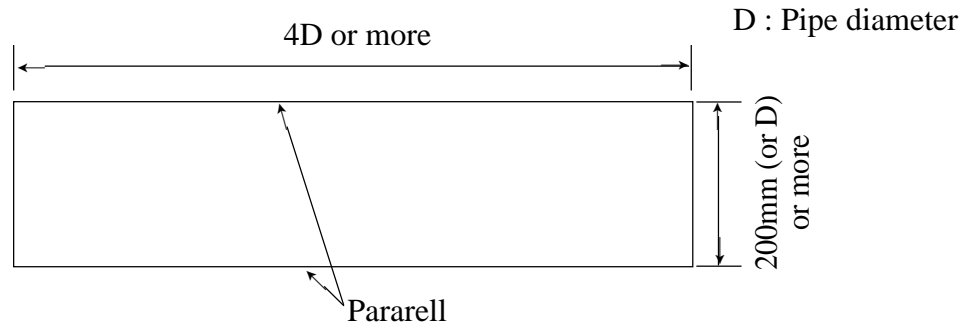

- ② Draw a line perpendicular to the long side at a point about  $100\text{mm}$  from one end.

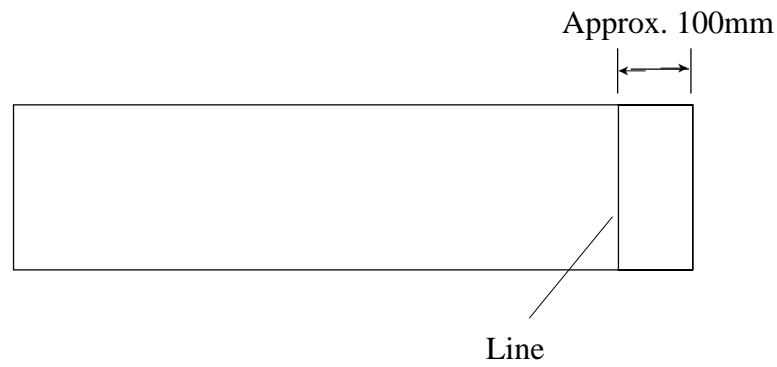

# APPENDIX 2. COMPOSITION OF KEY OPERATION

## 1. SETTING OF PIPING SPECIFICATIONS

FUNC ⇒ PIPE (7)		[ Initial value during shipment ]
PROCESS LINE SELECT NO. # (1, 2)		
# : SENSOR SPACING		
# : OUTER DIAMETER (13 to 6100mm)	Note) Entry of dimension of outer circumstance ⇒ Press “/π” key. ⇒ Converted into outer diameter	[ 60.05 mm ]
# : PIPE MATERIAL	<ul style="list-style-type: none"> <li>— CARBON STEEL</li> <li>— STAINLESS STEEL</li> <li>— PVC</li> <li>— COPPER</li> <li>— CAST IRON</li> <li>— ALUMINUM</li> <li>— FRP</li> <li>— ASBESTOS</li> <li>— DUCTILE IRON</li> <li>— PEEK</li> <li>— PVDF</li> <li>— ACRYLIC</li> <li>— OTHERS</li> </ul>	[ PVC ]
# : PIPE S.V. (1000 to 3700 m/s)	Note) Displayed when selecting “OTHERS” from the pipe materials.	[ 1000 m/s ]
# : WALL THICKNESS (0.1 to 100 mm)		[ 4.28 mm ]
# : LINING M.	<ul style="list-style-type: none"> <li>— NO LINING</li> <li>— TAR EPOXY</li> <li>— MORTAR</li> <li>— RUBBER</li> <li>— TEFLON</li> <li>— PYREX GLASS</li> <li>— PCV</li> <li>— OTHERS</li> </ul>	[ NO LINING ]
# : LINING S.V. (1000 to 3700 m/s)	Note) Displayed when selecting “OTHERS” from the lining materials.	[ 1000 m/s ]
# : LINING T. (0.1 to 100 mm)	Note) Displayed when selecting other than “NO LINING” from the lining materials.	[ 0.01 mm ]
# : KIND OF FLUID	<ul style="list-style-type: none"> <li>— WATER</li> <li>— SEA WATER</li> <li>— OTHERS</li> </ul>	[ WATER ]
# : FLUID S.V. (500 to 2500 m/s)	Note) Displayed when selecting “OTHERS” from the kind of fluid.	[ 500 m/s ]
# : VISCOSITY (0.01E-6 to 999.999E-6 m2/s)		[ 1.0038E-6 ]
# : SENSOR MOUNT.	<ul style="list-style-type: none"> <li>— V METHOD</li> <li>— Z METHOD</li> </ul>	[ V METHOD ]
# : SENSOR TYPE	<ul style="list-style-type: none"> <li>— FLW11</li> <li>— FLW12</li> <li>— FLW22</li> <li>— FLW32</li> <li>— FLW41</li> <li>— FLD12</li> <li>— FLW50</li> <li>— FLW51</li> </ul>	[ FLW12 ]
# : TRANS. VOLTAGE	<ul style="list-style-type: none"> <li>— 1 TIME</li> <li>— 2 TIMES</li> <li>— 4 TIMES</li> <li>— 8 TIMES</li> </ul>	[ 4 TIMES ]

## 2. SETTING OF OUTPUT

FUNC ⇒ RANGE (8)

RANGE SELECT No. # (1 to 3)

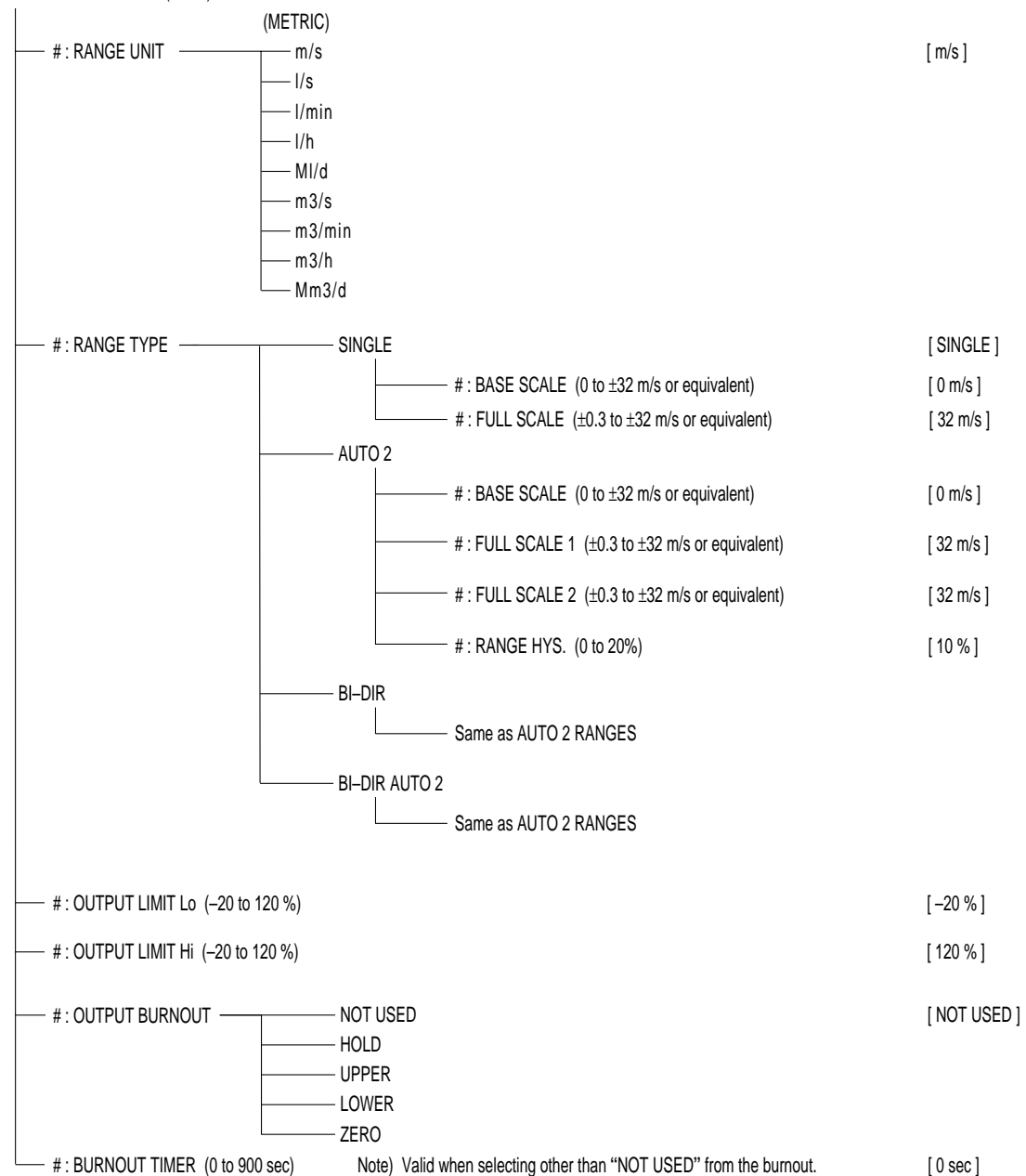

## 3. DAMPING

FUNC ⇒ DAMP (9)

DAMPING SELECT No. # (1 to 3)

# : DAMPING (0.0 to 100.0 sec) [ 0 sec ]

#### 4. ZERO ADJUSTMENT



#### 5. SETTING OF FLOW SWITCH



#### 6. SETTING OF TOTAL OUTPUT

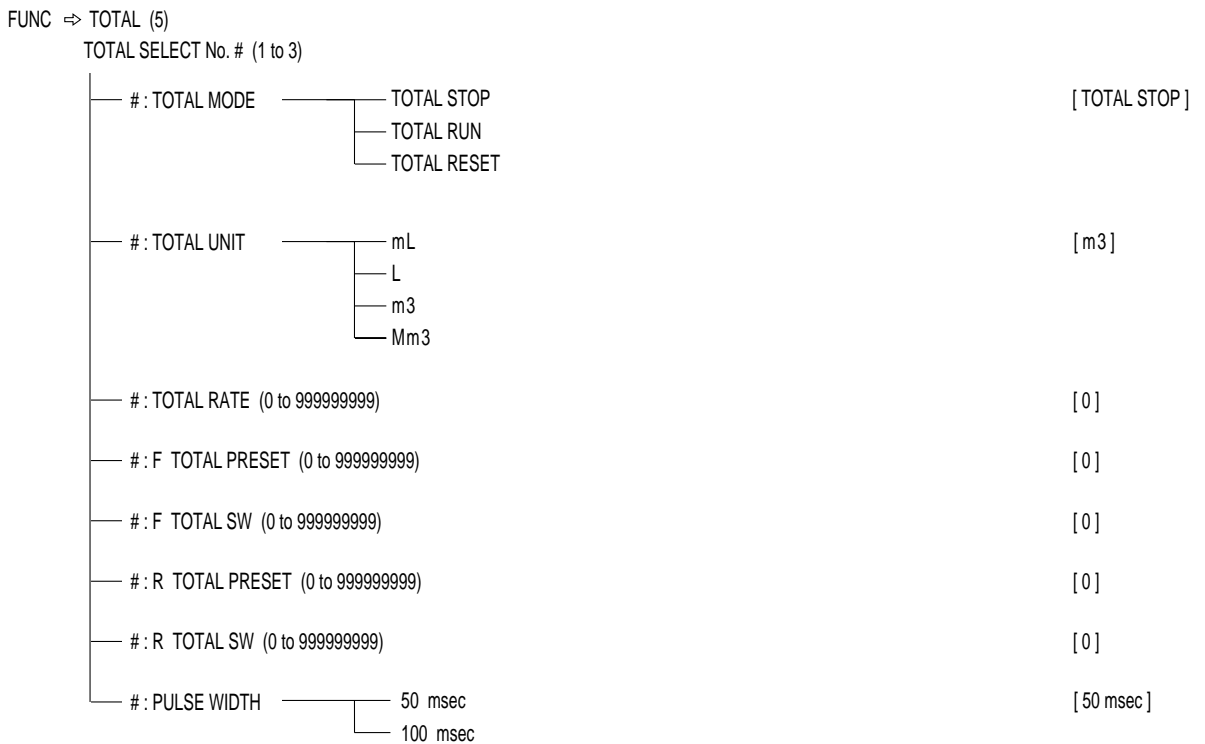

#### 7. SETTING OF LOW FLOW OUTPUT CUT



## 8. SETTING OF MEASURE DISPLAY

FUNC ⇒ DISP (·)

DISPLAY SELECT No. # (2 paths : 1 to 3), (2 pipes : 3), (1 path : 1)

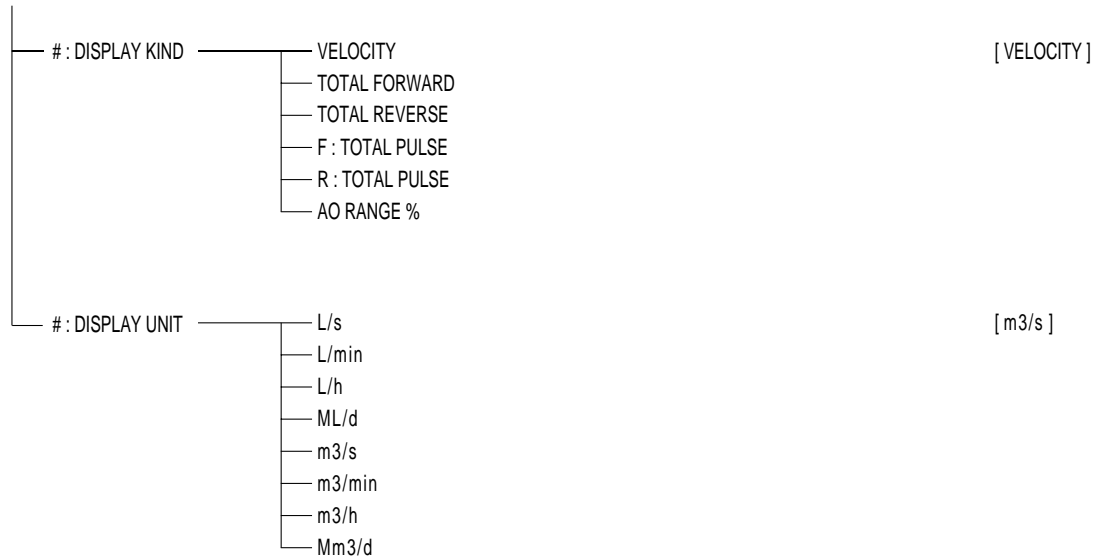

## 9. STATUS

FUNC ⇒ STATUS (1)

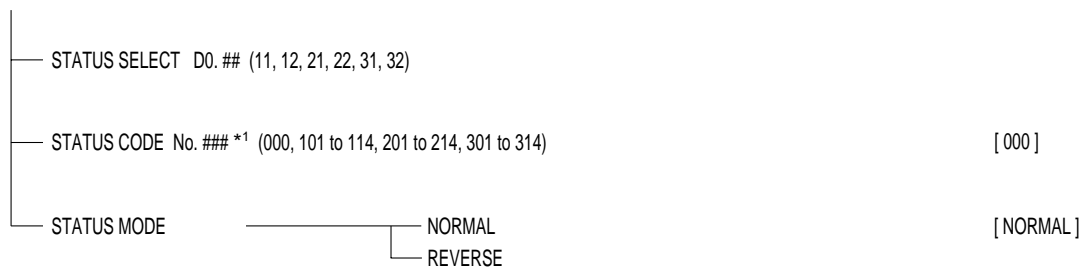

\*1 : STATUS CODE No. ###

- 000 : NOT USED
- \*01 : SIGNAL ERROR
- \*02 : F : TOTAL PULSE
- \*03 : R : TOTAL PULSE
- \*04 : F : TOTAL ALARM
- \*05 : R : TOTAL ALARM
- \*06 : F : TOTAL OVERFLOW
- \*07 : R : TOTAL OVERFLOW
- \*08 : FLOW SW HIGH
- \*09 : FLOW SW LOW
- \*10 : FULL SCALE 2
- \*11 : ANALOG OUTPUT RANGE OVER
- \*12 : TOTAL PULSE RANGE OVER
- \*13 : BUCKUP ERROR
- \*14 : FLOW DIRECTION

## 10. CALIBRATION OF MEASUREMENT VALUE

FUNC ⇒ CAL (2)

CALIBRATION SELECT No. # (1 to 3)



# 11. SYSTEM

FUNC ⇒ SYSTEM (3)

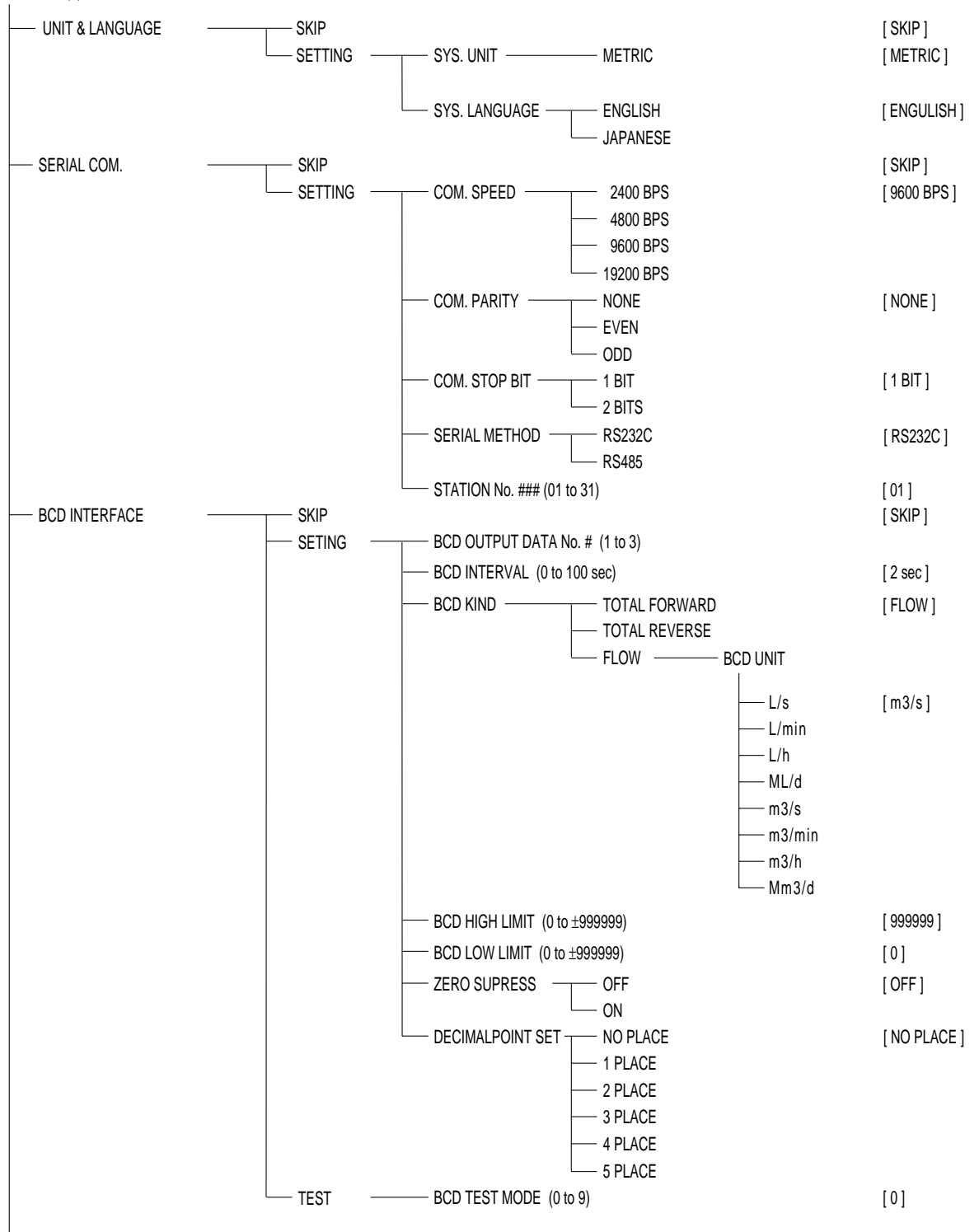

(Continued on next page)



(Continued from previous page)

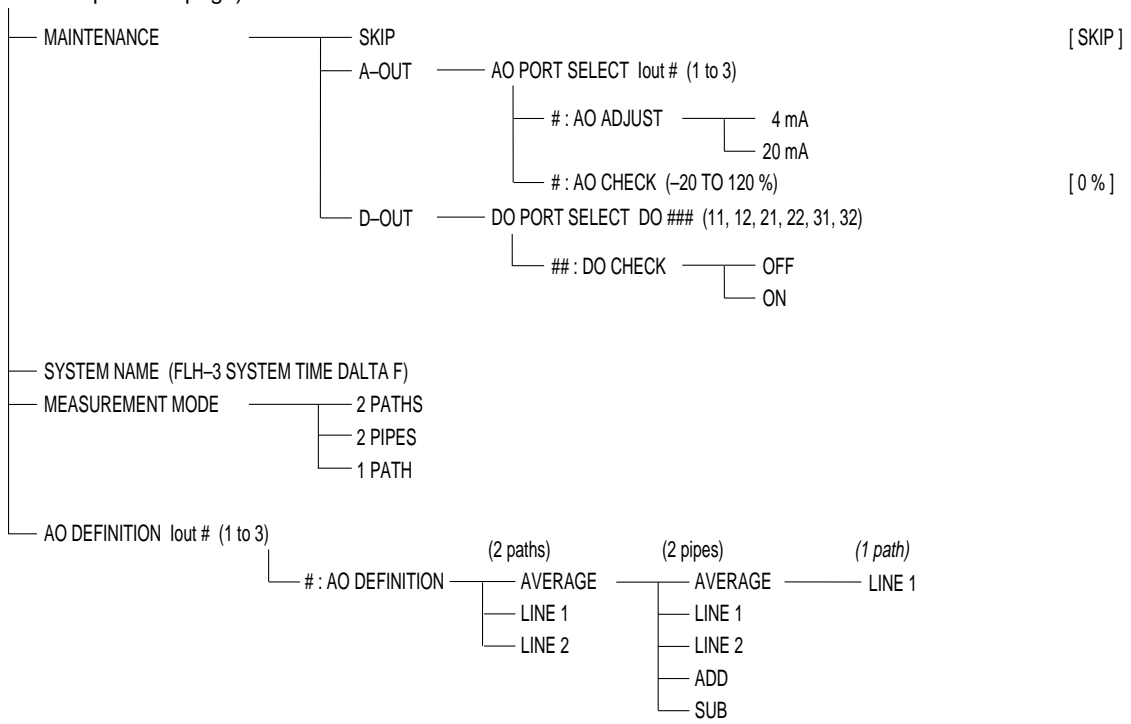

## 12. CHECK

FUNC ⇒ CHECK (±)

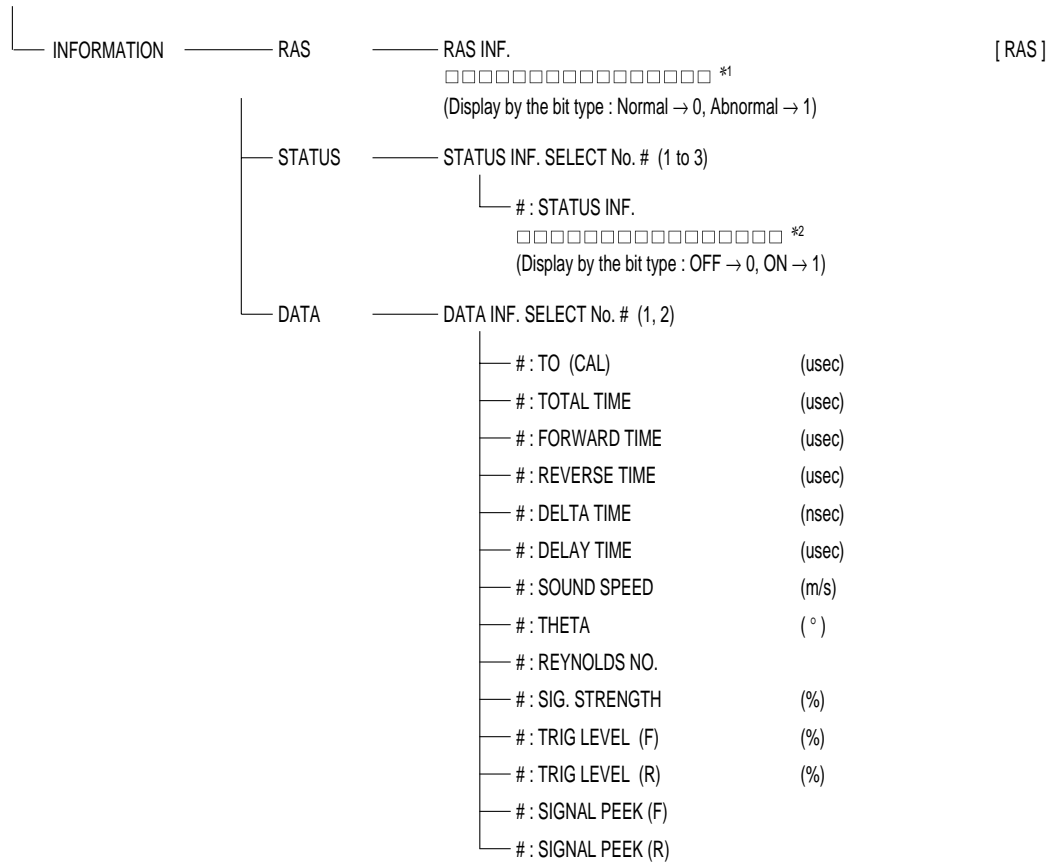

\*1 : RAS INFORMATION (Contents of bit)

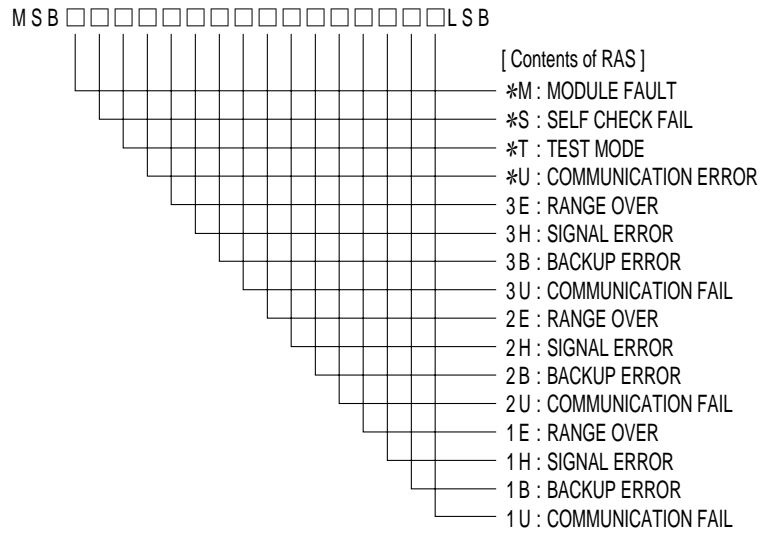

\*2 : STATUS INFORMATION (Contents of bit)

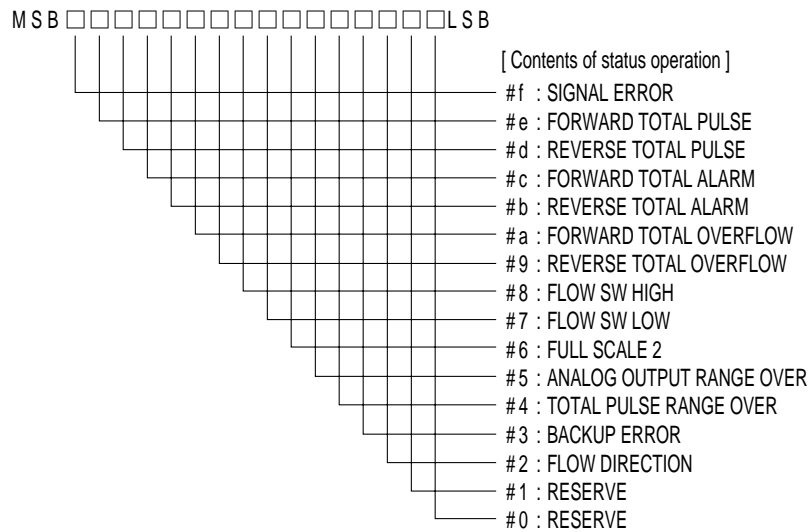

# APPENDIX 3. EXTERNAL COMMUNICATION SPECIFICATIONS

## 1. Communication specifications

Item		Specifications	
Communication interface		RS-232C	RS-485
Communication distance		15m	1km
Communication method		Half duplex start-stop synchronization	
Communication protocol		Message	
Communication speed		2400, 4800, 9600, 19200bps	
Communication mode		ASCII mode	
Data format	Start bit	1 bit	
	Data	ASCII expression (8 bits) in hexadecimal	
	Parity	None, odd and even	
	Stop bit	1 or 2 bits	
Error check		LRC (logical redundancy check)	

## 2. Message composition

### 2.1 Receiving

Composition	No. of bytes	Remarks
Start mark	1	: (3Ah)
Slave address (SLV)	2	01 to 31
Function code (F_CD)	4	See Function Code table
Error check	2	LRC
End mark	1	CR (0Dh)
	1	LF (0Ah)

### 2.2 Response

Composition	No. of bytes	Remarks
Start mark	1	: (3Ah)
Slave address (SLV)	2	01 to 31
Function code (F_CD)	4	See Function Code table
Length of data (L)	2	
Data	2L	
Error check	2	LRC
End mark	1	CR (0Dh)
	1	LF (0Ah)

### 2.3 Error response

Composition	No. of bytes	Remarks
Start mark	1	: (3Ah)
Slave address (SLV)	2	01 to 31
Function code (F_CD)	4	See Function Code table
Error data	2	See Error Data table
Error check	2	LRC
End mark	1	CR (0Dh)
	1	LF (0Ah)

Receiving format	:	SLV	F_CD	LRC	CR	LF		
Response format	:	SLV	F_CD	Data length	Data	LRC	CR	LF
Error response format	:	SLV	F_CD	Error data	LRC	CR	LF	

### 3. Error check

When adding all of the ASCII data except for “:”, “CR” and “LF” (Carry is not included), set LCR so that the result is 00h.

[ LCR creation procedure ]

- ① Add the data following the start mark (:) with carry excluded.
- ② Find the complement of “2” of the addition result.
- ③ Transform the complement result of 2 into ASCII. (=LRC)

### 4. Function code table

Contents	F_CD	Remarks
Instantaneous flow velocity (data 1 : single-path system)	0300	
Instantaneous flow velocity (data 2 : 2-path system)	0301	Invalid with single-path system
Instantaneous flow velocity (data 3 : calculation value)	0302	Invalid with 2-pipe and single-path systems
Instantaneous flow velocity (data 1 : single-path system)	0310	
Instantaneous flow velocity (data 2 : 2-path system)	0311	Invalid with single-path system
Instantaneous flow velocity (data 3 : calculation value)	0312	Invalid with single-path system
Forward integral value (data 1 : single-path system)	0320	
Forward integral value (data 2 : 2-path system)	0321	Invalid with single-path system
Forward integral value (data 3 : calculation value)	0322	Invalid with single-path system
Reverse integral value (data 1 : single-path system)	0330	
Reverse integral value (data 2 : 2-path system)	0331	Invalid with single-path system
Reverse integral value (data 3 : calculation value)	0332	Invalid with single-path system
Current output % (data 1 : single-line system)	0340	
Current output % (data 2 : 2-line system)	0341	Invalid with single-path system
Current output % (data 3 : calculation value)	0342	Invalid with single-path system
Status (data 1 : single-line system)	0100	
Status (data 2 : 2-path system)	0101	Invalid with single-path system
Status (data 3 : calculation value)	0102	Invalid with single-path system
RAS	0110	

Note) When an error occurs, the error response function code is as follows:

Function code: 0 3 0 2 → 8 3 0 2

### 5. Error code table

Error data	Remarks
01	Function code error (function code undefined)
02	LRC error
03	Reserved
04	Reserved
05	Reserved

---

## 6. Cable connection specifications (RS-232C)

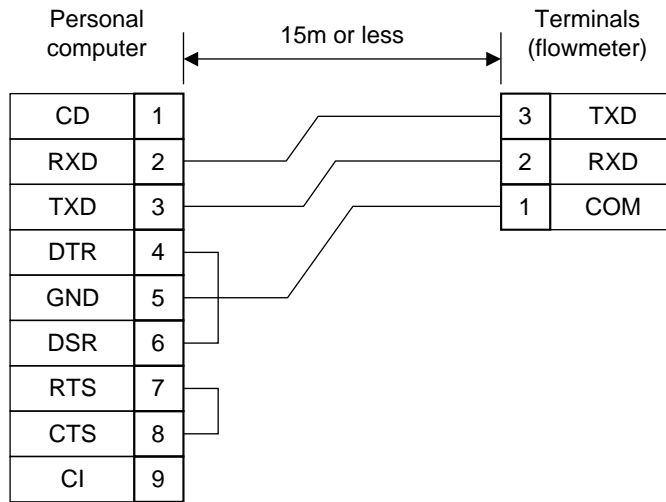

## APPENDIX 4. PIPING DATA

Stainless steel pipe for pipe arrangement (JIS G3459-1988)

Nominal diameter (mm)		Outer diameter (mm)	Normal thickness						
A	B		Schedule 5S	Schedule 10S	Schedule 20S	Schedule 40	Schedule 80	Schedule 120	Schedule 160
			Thickness (mm)	Thickness (mm)	Thickness (mm)	Thickness (mm)	Thickness (mm)	Thickness (mm)	Thickness (mm)
15	1/2	21.7	1.65	2.1	2.5	2.9	3.9	—	5.5
20	3/4	27.2	1.65	2.1	2.5	2.9	3.9	—	5.5
25	1	34.0	1.65	2.8	3.0	3.4	4.5	—	6.4
32	1 1/4	42.7	1.65	2.8	3.0	3.6	4.9	—	6.4
40	1 1/2	48.6	1.65	2.8	3.0	3.7	5.1	—	7.1
50	2	60.5	1.65	2.8	3.5	3.9	5.5	—	8.7
65	2 1/2	76.3	2.1	3.0	3.5	5.2	7.0	—	9.5
80	3	89.1	2.1	3.0	4.0	5.5	7.6	—	11.1
90	3 1/2	101.6	2.1	3.0	4.0	5.7	8.1	—	12.7
100	4	114.3	2.1	3.0	4.0	6.0	8.6	11.1	13.5
125	5	139.8	2.8	3.4	5.0	6.6	9.5	12.7	15.9
150	6	165.2	2.8	3.4	5.0	7.1	11.0	14.3	18.2
200	8	216.3	2.8	4.0	6.5	8.2	12.7	18.2	23.0
250	10	267.4	3.4	4.0	6.5	9.3	15.1	21.4	28.6
300	12	318.5	4.0	4.5	6.5	10.3	17.4	25.4	33.3
350	14	355.6	—	—	—	11.1	19.0	27.8	35.7
400	16	406.4	—	—	—	12.7	21.4	30.9	40.5
450	18	457.2	—	—	—	14.3	23.8	34.9	45.2
500	20	508.0	—	—	—	15.1	26.2	38.1	50.0
550	22	558.8	—	—	—	15.9	28.6	41.3	54.0
600	24	609.6	—	—	—	17.5	34.0	46.0	59.5
650	26	660.4	—	—	—	18.9	34.0	49.1	64.2

Polyethylene pipe for city water (JIS K6762-1982)

Nominal diameter (mm)	Outer diameter (mm)	1st type (Soft pipe)		2nd type (Hard pipe)	
		Thickness (mm)	Weight (kg/m)	Thickness (mm)	Weight (kg/m)
13	21.5	3.5	0.184	2.5	0.143
20	27.0	4.0	0.269	3.0	0.217
25	34.0	5.0	0.423	3.5	0.322
30	42.0	5.5	0.586	4.0	0.458
40	48.0	6.5	0.788	4.5	0.590
50	60.0	8.0	1.210	5.0	0.829

Galvanized steel pipe for city water SGPW (JIS G3442-1988)

Nominal pipe		Outer diameter (mm)	Thickness (mm)
(A)	(B)		
15	1/2	21.7	2.8
20	3/4	27.2	2.8
25	1	34.0	3.2
32	1 1/4	42.7	3.5
40	1 1/2	48.6	3.5
50	2	60.5	3.8
65	2 1/2	76.3	4.2
80	3	89.1	4.2
90	3 1/2	101.6	4.2
100	4	114.3	4.5
125	5	139.8	4.5
150	6	165.2	5.0
200	8	216.3	5.8
250	10	267.4	6.6
300	12	318.5	6.9

Asbestos cement pipe for city water (JIS A5301-1971)

Nominal diameter (mm)	1st type		2nd type		3rd type		4th type	
	Thickness of connected portion (mm)	Outer diameter of connected portion (mm)	Thickness of connected portion (mm)	Outer diameter of connected portion (mm)	Thickness of connected portion (mm)	Outer diameter of connected portion (mm)	Thickness of connected portion (mm)	Outer diameter of connected portion (mm)
50	10	70	—	—	—	—	—	—
75	10	95	—	—	—	—	—	—
100	12	124	10	120	9	118	—	—
125	14	153	11	147	9.5	144	—	—
150	16	182	12	174	10	170	—	—
200	21	242	15	230	13	226	11	222
250	23	296	19	288	15.5	281	12	274
300	26	352	22	344	18	336	14	328
350	30	410	25	400	20.5	391	16	382
400	35	470	29	458	23	446	18	436
450	39	528	32	514	26	502	20	490
500	43	586	35	570	28.5	557	22	544
600	52	704	42	684	34	668	26	652
700	—	—	49	798	39	778	30	760
800	—	—	56	912	44	888	34	868
900	—	—	—	—	49	998	38	976
1000	—	—	—	—	54	1108	42	1084
1100	—	—	—	—	59	1218	46	1192
1200	—	—	—	—	65	1330	50	1300
1300	—	—	—	—	73	1496	57	1464
1500	—	—	—	—	81	1662	63	1626

Polyethylene pipe for general use (JIS K6761-1979)

Nominal diameter (mm)	Outer diameter (mm)	1st type	2nd type
		Thickness (mm)	Thickness (mm)
13	21.5	2.7	2.4
20	27.0	3.0	2.4
25	34.0	3.0	2.6
30	42.0	3.5	2.8
40	48.0	3.5	3.0
50	60.0	4.0	3.5
65	76.0	5.0	4.0
75	89.0	5.5	5.0
100	114	6.0	5.5
125	140	6.5	6.5
150	165	7.0	7.0
200	216	8.0	8.0
250	267	9.0	9.0
300	318	10.0	10.0

Hi vinyl chloride pipe (city water pipe size)

Nominal diameter	Outer diameter	Thickness of pipe
13	18.0	2.5
20	26.0	3.0
25	32.0	3.5
30	38.0	3.5
40	48.0	4.0
50	60.0	4.5
75	89.0	5.8
100	114.0	7.0
125	140.0	7.5
150	165.0	8.5

Hi vinyl chloride pipe (conduit size)

Nominal pipe	Outer diameter	Thickness of pipe
28	34.0	3.0
35	42.0	3.5
41	48.0	3.5
52	60.0	4.0
65	76.0	4.5
78	89.0	5.5



Vertical type cast iron pipe (JISG5521)

Nominal pipe D	Thickness		Actual outer diameter D1
	T		
	Normal pressure pipe	Low pressure pipe	
75	9.0	—	93.0
100	9.0	—	118.0
150	9.5	9.0	169.0
200	10.0	9.4	220.0
250	10.8	9.8	271.6
300	11.4	10.2	322.8
350	12.0	10.6	374.0
400	12.8	11.0	425.6
450	13.4	11.5	476.8
500	14.0	12.0	528.0
600	15.4	13.0	630.8
700	16.5	13.8	733.0
800	18.0	14.8	836.0
900	19.5	15.5	939.0
1000	22.0	—	1041.0
1100	23.5	—	1144.0
1200	25.0	—	1246.0
1350	27.5	—	1400.0
1500	30.0	—	1554.0

Carbon steel pipe for pipe arrangement  
(JIS G3452-1988)

Nominal pipe		Outer diameter (mm)	Thickness (mm)
(A)	(B)		
15	1/2	21.7	2.8
20	3/4	27.2	2.8
25	1	34.0	3.2
32	1 1/4	42.7	3.5
40	1 1/2	48.6	3.5
50	2	60.5	3.8
65	2 1/2	76.3	4.2
80	3	89.1	4.2
90	3 1/2	101.6	4.2
100	4	114.3	4.5
125	5	139.8	4.5
150	6	165.2	5.0
175	7	190.7	5.3
200	8	216.3	5.8
225	9	241.8	6.2
250	10	267.4	6.6
300	12	318.5	6.9
350	14	355.6	7.9
400	16	406.4	7.9
450	18	457.2	7.9
500	20	508.0	7.9

Hard vinyl chloride pipe (JIS K6741-1984)

Section Nominal pipe (mm)	VP		VU	
	Outer diameter	Thickness	Outer diameter	Thickness
13	18	2.2	—	—
16	22	2.7	—	—
20	26	2.7	—	—
25	32	3.1	—	—
30	38	3.1	—	—
40	48	3.6	48	1.8
50	60	4.1	60	1.8
65	76	4.1	76	2.2
75	89	5.5	89	2.7
100	114	6.6	114	3.1
125	140	7.0	140	4.1
150	165	8.9	165	5.1
200	216	10.3	216	6.5
250	267	12.7	267	7.8
300	318	15.1	318	9.2
350	—	—	370	10.5
400	—	—	420	11.8
450	—	—	470	13.2
500	—	—	520	14.6
600	—	—	630	17.8
700	—	—	732	21.0
800	—	—	835	23.9

Steel pipe coated for city water  
STPW (JIS G3443-1968)

Nominal diameter (A)	Outer diameter (mm)	Thickness (mm)
80	89.1	4.2
100	114.3	4.5
125	139.8	4.5
150	165.2	5.0
200	216.3	5.8
250	267.4	6.6
300	318.5	6.9
350	355.6	6.0
400	406.4	6.0
450	457.2	6.0
500	508.0	6.0
600	609.6	6.0
700	711.2	6.0
800	812.8	7.1
900	914.4	7.9
1000	1016.0	8.7
1100	1117.6	10.3
1200	1219.2	11.1
1350	1371.6	11.9
1500	1524.0	12.7

Steel pipe coated for city water STW (JIS G3443 1987)

Nominal diameter A	Outer diameter mm	Kinds of symbol				Kinds of symbol			
		STW 30	STW 38	STW 41		STW 290	STW 370	STW 400	
				Nominal thickness				Nominal thickness	
				A	B			A	B
		Thickness (mm)	Thickness (mm)	Thickness (mm)	Thickness (mm)	Thickness (mm)	Thickness (mm)	Thickness (mm)	Thickness (mm)
80	89.1	4.2	4.5	—	—	4.2	4.5	—	—
100	114.3	4.5	4.9	—	—	4.5	4.9	—	—
125	139.8	4.5	5.1	—	—	4.5	5.1	—	—
150	165.2	5.0	5.5	—	—	5.0	5.5	—	—
200	216.3	5.8	6.4	—	—	5.8	6.4	—	—
250	267.4	6.6	6.4	—	—	6.6	6.4	—	—
300	318.5	6.9	6.4	—	—	6.9	6.4	—	—
350	355.6	—	—	6.0	—	—	—	6.0	—
400	406.4	—	—	6.0	—	—	—	6.0	—
450	457.2	—	—	6.0	—	—	—	6.0	—
500	508.0	—	—	6.0	—	—	—	6.0	—
600	609.6	—	—	6.0	—	—	—	6.0	—
700	711.2	—	—	7.0	6.0	—	—	7.0	6.0
800	812.8	—	—	8.0	7.0	—	—	8.0	7.0
900	914.4	—	—	8.0	7.0	—	—	8.0	7.0
1000	1016.0	—	—	9.0	8.0	—	—	9.0	8.0
1100	1117.6	—	—	10.0	8.0	—	—	10.0	8.0
1200	1219.2	—	—	11.0	9.0	—	—	11.0	9.0
1350	1371.6	—	—	12.0	10.0	—	—	12.0	10.0
1500	1524.0	—	—	14.0	11.0	—	—	14.0	11.0
1600	1625.6	—	—	15.0	12.0	—	—	15.0	12.0
1650	1676.4	—	—	15.0	12.0	—	—	15.0	12.0
1800	1828.8	—	—	16.0	13.0	—	—	16.0	13.0
1900	1930.4	—	—	17.0	14.0	—	—	17.0	14.0
2000	2032.0	—	—	18.0	15.0	—	—	18.0	15.0
2100	2133.6	—	—	19.0	16.0	—	—	19.0	16.0
2200	2235.2	—	—	20.0	16.0	—	—	20.0	16.0
2300	2336.8	—	—	21.0	17.0	—	—	21.0	17.0
2400	2438.4	—	—	22.0	18.0	—	—	22.0	18.0
2500	2540.0	—	—	23.0	18.0	—	—	23.0	18.0
2600	2641.6	—	—	24.0	19.0	—	—	24.0	19.0
2700	2743.2	—	—	25.0	20.0	—	—	25.0	20.0
2800	2844.8	—	—	26.0	21.0	—	—	26.0	21.0
2900	2946.4	—	—	27.0	21.0	—	—	27.0	21.0
3000	3048.0	—	—	29.0	22.0	—	—	29.0	22.0

Centrifugal nodular graphite cast iron pipe for city water (A type) (JWWA G-105 1971)

Nominal diameter D	Thickness of pipe T			Actual outer diameter D1
	1st type pipe	2nd type pipe	3rd type pipe	
75	7.5	—	6.0	93.0
100	7.5	—	6.0	118.0
150	9.5	—	6.0	169.0
200	7.5	—	6.0	220.0
250	7.5	—	6.0	271.6
300	7.5	—	6.5	332.8
350	7.5	—	6.5	374.0
400	8.5	7.5	7.0	425.6
450	9.0	8.0	7.5	476.8
500	9.5	8.5	7.0	528.0

Centrifugal nodular graphite cast iron pipe for city water (K type) (JWWA G-105 1971)

Nominal diameter D	Thickness of pipe			Actual outer diameter D1
	1st type pipe	2nd type pipe	3rd type pipe	
400	8.5	7.5	7.0	425.6
450	9.0	8.0	7.5	476.8
500	9.5	8.5	8.0	528.0
600	11.0	10.0	9.0	630.8
700	12.0	11.0	10.0	733.0
800	13.5	12.0	11.0	836.0
900	15.0	13.0	12.0	939.0
1000	16.5	14.5	13.0	1041.0
1100	18.0	15.5	14.0	1144.0
1200	19.5	17.0	15.0	1246.0
1350	21.5	18.5	16.5	1400.0
1500	23.5	20.5	18.0	1554.0

Ductile iron specials

Nominal diameter (mm)	Thickness of pipe (mm)
75	8.5
100	8.5
150	9.0
200	11.0
250	12.0
300	12.5
350	13.0
400	14.0
450	14.5
500	15.0
600	16.0
700	17.0
800	18.0
900	19.0
1000	20.0
1100	21.0
1200	22.0
1350	24.0
1500	26.0
1600	27.5
1650	28.0
1800	30.0
2000	32.0
2100	33.0
2200	34.0
2400	36.0

Dimensions of centrifugal sand mold cast iron pipe (JIS G5522)

Nominal diameter D	Thickness of pipe T			Actual outer diameter D <sub>2</sub>
	High pressure pipe	Normal pressure pipe	Low pressure pipe	
75	9.0	7.5	—	93.0
100	9.0	7.5	—	118.0
125	9.0	7.8	—	143.0
150	9.5	8.0	7.5	169.0
150	9.5	8.0	7.5	169.0
200	10.0	8.8	8.0	220.0
250	10.8	9.5	8.4	271.6
300	11.4	10.0	9.0	322.8
350	12.0	10.8	9.4	374.0
400	12.8	11.5	10.0	425.6
450	13.4	12.0	10.4	476.8
500	14.0	12.8	11.0	528.0
600	—	14.2	11.8	630.8
700	—	15.5	12.8	733.0
800	—	16.8	13.8	836.0
900	—	18.2	14.8	939.0

Arc welded big diameter stainless steel pipe for pipe arrangement (JIS G3468-1988)

Nominal diameter		Outer diameter (mm)	Nominal thickness			
			Schedule 5S	Schedule 10S	Schedule 20S	Schedule 40S
A	B		Thickness (mm)	Thickness (mm)	Thickness (mm)	Thickness (mm)
150	6	165.2	2.8	3.4	5.0	7.1
200	8	216.3	3.4	4.0	6.5	9.3
250	10	267.4	4.0	4.5	6.5	10.3
350	14	355.6	4.0	5.0	8.0	11.1
400	16	406.4	4.5	5.0	8.0	12.7
450	18	457.2	4.5	5.0	8.0	14.3
500	20	508.0	5.0	5.5	9.5	15.1
550	22	558.8	5.0	5.5	9.5	15.1
600	24	609.6	5.5	6.5	9.5	17.5
650	26	660.4	5.5	8.0	12.7	17.5
700	28	711.2	5.5	8.0	12.7	17.5
750	30	762.0	6.5	8.0	12.7	17.5
800	32	812.8	—	8.0	12.7	17.5
850	34	863.6	—	8.0	12.7	17.5
900	36	914.1	—	8.0	12.7	19.1
1000	40	1016.0	—	9.5	14.3	26.2

Arc welded carbon steel pipe (JIS G3457-1976)

Nominal diameter		Thickness (mm)	6.0	6.4	7.1	7.9	8.7	9.5	10.3	11.1	11.9	12.7	13.1	15.1	15.9
(A)	(B)														
		Outer diameter (mm)													
350	14	355.6	51.7	55.1	61.0	67.7									
400	16	406.4	59.2	63.1	66.9	77.6									
450	18	457.2	66.8	71.1	78.8	87.5									
500	20	508.0	74.3	79.2	87.7	97.4	107	117							
550	22	558.8	81.8	87.2	96.6	107	118	129	139	150	160	171			
600	24	609.6	89.0	95.2	105	117	127	141	152	164	175	187			
650	26	660.4	96.8	103	114	127	140	152	165	178	190	203			
700	28	711.2	104	111	123	137	151	164	178	192	205	219			
750	30	762.0		119	132	147	162	176	191	206	220	235			
800	32	812.8		127	141	157	173	188	204	219	235	251	258	297	312
850	34	863.6		135		167	183	200	219	233	250	266	275	315	332
900	36	914.4		143		177	194	212	230	247	265	282	291	335	352
1000	40	1016.0				196	216	236	255	275	295	314	324	373	392
1100	44	1117.6						260	281	303	324	346	357	411	432
1200	48	1219.2						283	307	331	354	378	390	448	472
1350	54	1371.6									399	426	439	505	532
1500	60	1524.0									444	473	488	562	591
1600	64	1625.6											521	600	631
1800	72	1828.8											587	675	711
2000	80	2032.0												751	799

Dimensions of centrifugal mold cast iron pipe (JIS G5523 1977)

Nominal diameter (mm)	Thickness of pipe T		Actual outer diameter D <sub>1</sub>
	High pressure pipe	Normal pressure pipe	
75	9.0	7.5	93.0
100	9.0	7.5	118.0
125	9.0	7.8	143.0
150	9.5	8.0	169.0
200	10.0	8.8	220.0
250	10.8	9.5	271.6
300	11.4	10.0	322.8

Hard vinyl chloride pipe for city water (JIS K6742-1975)

Nominal diameter	Outer diameter	Thickness
13	18	2.5
20	26	3.0
25	32	3.5
30	38	3.5
40	48	4.0
50	60	4.5
75	89	5.9
100	114	7.1
150	165	9.6

Cast iron pipe for waste water (JIS G5525)

Nominal diameter	Thickness of pipe	Actual inner diameter	Actual outer diameter
	T	D <sub>1</sub>	D <sub>2</sub>
50	6.0	50	62
65	6.0	65	77
75	6.0	74	87
100	6.0	100	112
125	6.0	125	137
150	6.0	150	162
200	7.0	200	214

(a) Velocity of sound subject to change of temperature in water (0 to 100°C)

T °C	V m/s	T °C	V m/s	T °C	V m/s	T °C	V m/s
0	1402.74						
1	1407.71	26	1499.64	51	1543.93	76	1555.40
2	1412.57	27	1502.20	52	1544.95	77	1555.31
3	1417.32	28	1504.68	53	1545.92	78	1555.18
4	1421.98	29	1507.10	54	1546.83	79	1555.02
5	1426.50	30	1509.44	55	1547.70	80	1554.81
6	1430.92	31	1511.71	56	1548.51	81	1554.57
7	1435.24	32	1513.91	57	1549.28	82	1554.30
8	1439.46	33	1516.05	58	1550.00	83	1553.98
9	1443.58	34	1518.12	59	1550.68	84	1553.63
10	1447.59	35	1520.12	60	1551.30	85	1553.25
11	1451.51	36	1522.06	61	1551.88	86	1552.82
12	1455.34	37	1523.93	62	1552.42	87	1552.37
13	1459.07	38	1525.74	63	1552.91	88	1551.88
14	1462.70	39	1527.49	64	1553.35	89	1551.35
15	1466.25	40	1529.18	65	1553.76	90	1550.79
16	1469.70	41	1530.80	66	1554.11	91	1550.20
17	1473.07	42	1532.37	67	1554.43	92	1549.58
18	1476.35	43	1533.88	68	1554.70	93	1548.92
19	1479.55	44	1535.33	69	1554.93	94	1548.23
20	1482.66	45	1536.72	70	1555.12	95	1547.50
21	1485.69	46	1538.06	71	1555.27	96	1546.75
22	1488.63	47	1539.34	72	1555.37	97	1545.96
23	1491.50	48	1540.57	73	1555.44	98	1545.14
24	1494.29	49	1541.74	74	1555.47	99	1544.29
25	1497.00	50	1542.87	75	1555.45	100	1543.41

Note) T: temperature, V: velocity of sound

(b) Velocity of sound and density of various liquids

Name of liquid	T °C	$\rho$ g/cm <sup>3</sup>	V m/s
Acetone	20	0.7905	1190
Aniline	20	1.0216	1659
Alcohol	20	0.7893	1168
Ether	20	0.7135	1006
Ethylene glycol	20	1.1131	1666
n-octane	20	0.7021	1192
o-xylene	20	0.871	1360
Chloroform	20	1.4870	1001
Chlorobenzene	20	1.1042	1289
Glycerin	20	1.2613	1923
Acetic acid	20	1.0495	1159
Methyl acetate	20	0.928	1181
Ethyl acetate	20	0.900	1164
Cyclohexane	20	0.779	1284
Dithionic acid	20	1.033	1389
Heavy water	20	1.1053	1388
Carbon tetrachloride	20	1.5942	938
Mercury	20	13.5955	1451
Nitrobenzene	20	1.207	1473
Carbon disulfide	20	1.2634	1158
Chloroform	20	2.8904	931
n-propyl alcohol	20	0.8045	1225
n-pentane	20	0.6260	1032
n-hexane	20	0.654	1083
Light oil	25	0.81	1324
Transformer oil	32.5	0.859	1425
Spindle oil	32	0.905	1342
Petroleum	34	0.825	1295
Gasoline	34	0.803	1250
Water	13.5	1.	1460
Sea water (salinity: 35%)	16	1.	1510

Note) T: temperature,  $\rho$ : density, V: velocity of sound

(c) Velocity of sound per piping material

Material	V m/s
Iron	3230
Steel	3206
Ductile cast iron	3000
Cast iron	2460
Stainless steel	3206
Copper	2260
Lead	2170
Aluminum	3080
Brass	2050
Vinylchloride	2640
Acrylics	2644
FRP	2505
Mortar	2500
Tar epoxy	2505
Polyethylene	1900
Teflon	1240

Note) V: velocity of sound

(d) Dynamic viscosity coefficient of various liquids

Name of liquid	T °C	$\rho$ g/cm <sup>3</sup>	V m/s	$\nu$ ( $\times 10^{-6}$ m <sup>2</sup> /s)
Acetone	20	0.7905	1190	0.407
Aniline	20	1.0216	1659	1.762
Ether	20	0.7135	1006	0.336
Ethylene glycol	20	1.1131	1666	21.112
Chloroform	20	1.4870	1001	0.383
Glycerin	20	1.2613	1923	11.885
Acetic acid	20	1.0495	1159	1.162
Methyl acetate	20	0.928	1181	0.411
Ethyl acetate	20	0.900	1164	0.499
Heavy water	20	1.1053	1388	1.129
Carbon tetrachloride	20	1.5942	938	0.608
Mercury	20	13.5955	1451	0.114
Nitrobenzene	20	1.207	1473	1.665
Carbon disulfide	20	1.2634	1158	0.290
n-pentane	20	0.6260	1032	0.366
n-hexane	20	0.654	1083	0.489
Spindle oil	32	0.905	1324	15.7
Gasoline	34	0.803	1250	0.4~0.5
Water	13.5	1.	1460	1.004(20°C)

Note) T: temperature,  $\rho$ : density, V: velocity of sound  
 $\nu$ : kinematic viscosity

# Hotline

**Tel. +49-7025-9208-0 or -79**  
**Fax +49-7025-9208-15**



®

**Badger Meter Europa GmbH**

Subsidiary of Badger Meter, Inc.

Nürtinger Strasse 76  
72639 Neuffen (Germany)  
E-mail: [badger@badgermeter.de](mailto:badger@badgermeter.de)  
[www.badgermeter.de](http://www.badgermeter.de)