



DYNASONICS

Series 90 I

Enhanced Ultrasonic flow Meter

Operations & Maintenance
Manual

REV 4/02

QUICK-START OPERATING INSTRUCTIONS

This manual contains detailed operating instructions for all aspects of the D901/M instrument. The following condensed instructions are provided to assist the operator in getting the instrument started up and running as quickly as possible. This pertains to basic operation only. If specific instrument features are to be used or if the installer is unfamiliar with this type of instrument, refer to the appropriate section in the manual for complete details.

Location

1. TRANSDUCER LOCATION

- A. Determine the appropriate mounting location for the transducers by referring to **Figure 1**.

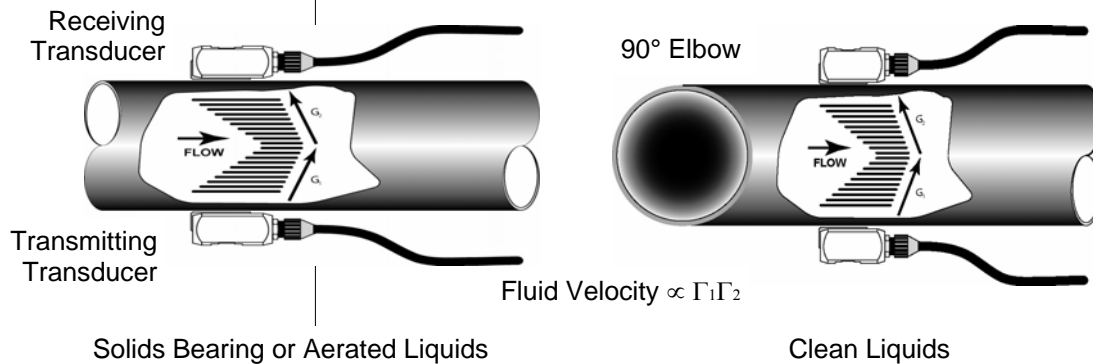

Figure 1 Transducer Locations

Pipe Preparation and Mounting

2. PIPE PREPARATION AND TRANSDUCER MOUNTING

- A. The piping surface, where the transducers are to be mounted, needs to be clean and dry. Remove loose scale, rust and paint to ensure satisfactory acoustical bonds.
- B. Connect the mounting straps around the pipe. Leave the strap loose enough to slip the transducers underneath.
- C. Apply a liberal amount of silicone rubber (enclosed) onto the transducer faces and the prepared areas of the pipe.

QUICK-START OPERATING INSTRUCTIONS

- D. Place each transducer under the mounting strap, 180° apart on the pipe. Ensure that the transducer cables are facing the same direction. See **Figure 2**.

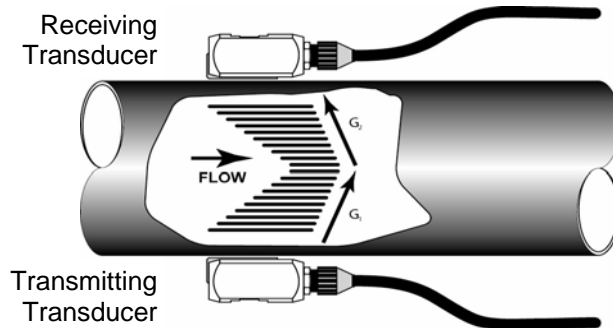

Figure 2 Transducer

- E. Route the transducer cable back to the transmitter, avoiding locations near high voltage supply wires.

Connections

3. TRANSDUCER CONNECTION

- A. Do not attempt to add additional cable to the transducers.
- B. Connect the spade terminals to the appropriate terminal block within the transmitter.

4. INITIAL SETTINGS AND POWER UP

- A. Set the SENSITIVITY control to - 2.
- B. Apply AC power. The POWER indicator will illuminate.
- C. If the pipe is full of a flowing liquid, the SIGNAL STRENGTH meter will indicate and the READ indicator will illuminate.
- D. Adjust the SENSITIVITY control so that the right-most green LED just comes ON.
- E. The default display indicates fluid velocity as either FPS or MPS. Refer to the appropriate place in this manual for specific features and options.

Startup

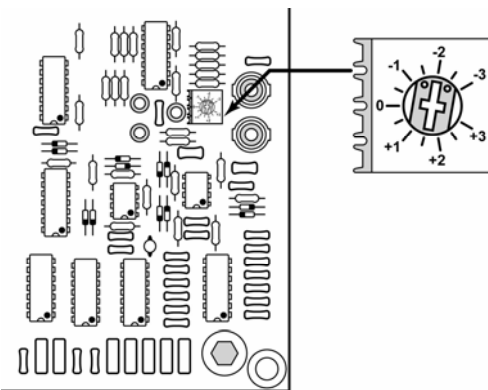

TABLE OF CONTENTS

	Pages
	1-2
Part 1 - Introduction	
Quick-Start Operating Instructions	1-2
Introduction	
General	5
Applications	5
Model Matrix	6
	7-8
Part 2 - Installation	
Bench Test Procedure	9
Installation	
Transducer Mounting Locations	10-12
Pipe Preparation	13
Transducer Mounting	13-15
Transmitter Mounting	16-17
Electrical Connections	17-19
Part 3 - Startup and Configuration	
Instrument Startup and Configuration	
Initial Settings	20
Modes of Operation	21
Pipe I.D. Input	22
Full Scale Input	23
Totalizer Exponent Input	24
Engineering Units Input	25

TABLE OF CONTENTS

		Pages
Part 4 - Troubleshooting	Instrument Startup and Configuration	
	CAL. Constant Input	26
	Display Damping	27
	System Damping	27
	TEST Diagnostic Key	27
	System and Totalizer RESET	28
	Totalizer Reset	28
	Trouble Shooting Guide	29-30
	Appendices	31+
	Face Plate Drawing	
	Intrinsically Safe Installation	
	High-Temperature Transducers	
	Clean Liquid Installation Guide	
	Multiple Unit Cross-talk	
	Pipe Dimension Chart: Cast Iron	
	Pipe Dimension Chart: ST, SS, PVC	
	Velocity to Volumetric Conversion	
	Statement of Warranty	
Customer Service		

PART 1 - INTRODUCTION

General

The D901/M ultrasonic flow meter is designed to measure the fluid velocity of liquid within closed conduit. The transducers are a non-contacting, clamp-on type, which will provide benefits of non-fouling operation and ease of installation.

The flow meter operates by transmitting an ultrasonic sound from its transmitting transducer through the pipe wall into the flowing liquid. The sound will be reflected by suspended particles or bubbles within the liquid and recorded by the receiving transducer. A frequency shift (Doppler effect) will occur that is directly related to the speed of the moving particle or bubble. This shift in frequency is interpreted by the instrument and converted to various user defined measuring units.

A unique feature of this product is that it employs a proprietary digital filtering system and recognition circuit. This feature allows the instrument to measure fluid velocities of clean liquids if the transducers are mounted downstream from a 90° elbow. The non-symmetrical hydraulic turbulence which occurs downstream of an elbow is captured, linearized and can be displayed as liquid velocity and volume. This capability is not available in conventional Doppler technology.

Application Versatility

The D901/M flow meter can be successfully applied on a wide range of metering applications. The simple to program transmitter allows the standard product to be used on pipe sizes ranging from 1 - 120 inch [25 - 3050 mm] pipe I.D. (With the small pipe transducer option, the pipe size range is 0.25 - 1 inch [6 - 25 mm]). A variety of liquid applications can be accommodated: raw sewage, reclaimed water, river water, plant effluent, mining slurries, sludge, etc. Because the transducers are non-contacting and have no moving parts, the flow meter is not affected by system pressure, fouling or wear. Standard transducers are rated to 250°F [121°C]. Optional high temperature transducers are rated to operate to 400°F [204°C].

PART 1 - INTRODUCTION

User Safety

The D901/M employs modular construction and provides electrical safety for the operator. The display face contains voltages no greater than 9 Vdc and the metal work is electrically connected to Earth Ground. The display face swings open to allow access to user connections.

Battery Backup

A rechargeable nickel-cadmium battery on the back of the display board retains all user-entered configuration values in memory for several years (at 25°C), even if power is lost or turned off. The ten year battery is continually trickle charged whenever line power is applied. A completely discharged battery recharges fully after 48 hours of instrument operation.

Product Identification

The serial number and complete model number of your D901/M is located on the inside of the transmitter's front cover. Should technical assistance be required, please provide the Dynasoncs' Customer Service Department with this information.

Product Matrix

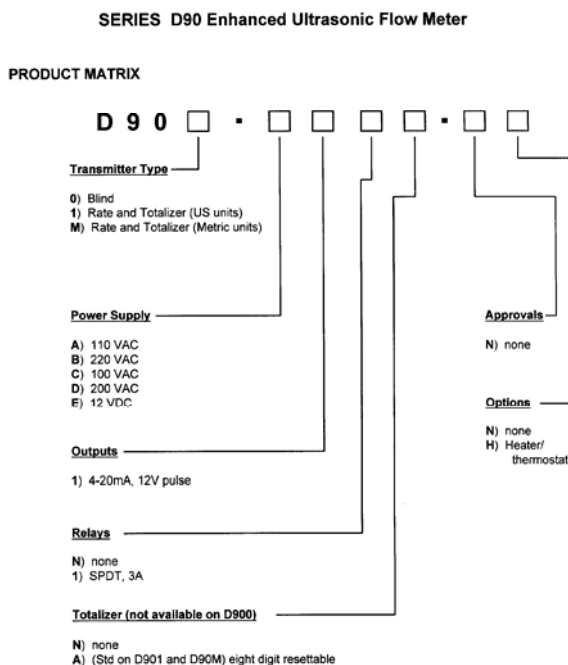

PART 1 - SPECIFICATIONS

Ambient Conditions	<p><i>Transmitter</i> - -22 to 160°F [- 30 to 70 °C], 0-95% relative humidity, non-condensing.</p> <p><i>Transducers</i> - - 40° to 250°F [-40° to 121° C] Standard. Optional: - 40° to 400°F [- 40° to 204°C]</p>
Display	2 line x 20 character alphanumeric LCD, back lit. Digit height 0.2 inches [5 mm]
Transducer to Transmitter Distance	Standard: 20 feet [6.09 meters], flexible armored conduit. Optional lengths to 300 feet [100 meters]
Power Requirements	115/230 VAC 50/60 Hz ± 10%. Optional: 100/200 VAC 50/60 Hz ± 10% and 12VDC. Power consumption less than 12 VA.
Pipe Sizes	<p>1 - 120 inches [25 - 3050 mm] Pipe I.D.</p> <p>Optional: 0.25 - 1 inch [6 – 25 mm], Small Pipe Transducer</p>
Velocity	0.5 - 20 FPS [0.15 - 6.08 MPS]
Measuring Units	FPS, GPM, MGD [MPS, LPM, M ³ /Hr]
Indicators	Power, Signal Strength, Fault, Over-range, Read, Flow Analyzer
Liquid Requirements	<p>25 ppm of 30 micron* suspended solids or bubbles.</p> <p>* Less than this minimum will require transducer mount downstream of a 90°</p>

PART 1 - SPECIFICATIONS

Outputs	4-20 mA, 600 Ohms max., Isolated. 12 Vdc pulse, 50 mS duration, 0-0.15 Hz to 0-2.5 Hz, user adjustable.
Non-linearity	±2 % Full Scale
Sensitivity	0.4 % of Full Scale
Repeatability	±0.4% of Full Scale
Response Time	5-50 seconds, user configured adjustable, to 90% of value, step change in flow.
Enclosure	NEMA 4X, [IP-65] Fiberglass w/SS hardware.
Size	13.5H x 11.3W x 5.60D inches [343H x 287W x 141D mm]
Mounting	Wall mount
Weather Shield	Optional weather visor; Dynasonics P.N. D003-899-001
Net Weight	15 lbs. [6.8 Kg]

PART 2 - PRE-INSTALLATION CHECKOUT

Unpacking

After unpacking, it is recommended to save the shipping carton and packing materials in case the instrument is stored or re-shipped. Inspect the equipment and carton for damage. If there is evidence of shipping damage, notify the carrier immediately.

Functional Test

The D901/M flow meter can be checked for basic functionality using the following **Bench Test** procedure. It is recommended that this operation be performed before installing the transducers or transmitter permanently.

Procedure:

1. Open the D901/M transmitter enclosure and the inner display door.
2. Connect the transducer cable terminals to the corresponding terminal block locations within the transmitter. See **Figure 3**.
3. Set the transmitter SENSITIVITY control [located on the display door] to -2.
4. Apply power.
5. Hold the transducers, the flat sides facing each other, approximately 6-8 inches [150-200 mm] apart.
6. Move the transducers towards and away from each other 1 inch [25mm] for several cycles at approximately 1 second interval.
7. If unit is functioning properly, the READ LED will illuminate and the rate display will indicate flow readings.

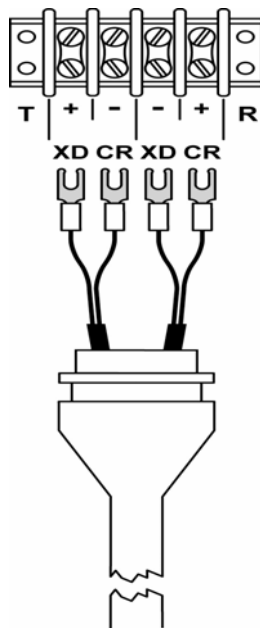

Figure 3

Bench Test is Complete

PART 2 - TRANSDUCER INSTALLATION

Transducer Mounting Considerations

The transducers that are utilized by the D901/M contain piezo electric crystals for transmitting and receiving ultrasonic sound energy through the pipe wall.

The transducers can be mounted in three different configurations. The selection of the proper configuration is dependent on the liquid to be measured characteristics.

The three liquid characteristics, which will affect mounting location and orientation, are as follows:

Step A - Mounting Locations

CASE 1: Liquid that contains 25 to 10,000 PPM [1%] of 30 micron or larger suspended solids or aeration.

CASE 2: Liquid that contains greater than 10,000 PPM [1%] of 30 micron or larger suspended solids or aeration.

CASE 3: Liquid that contains fewer than 25 PPM of 30 micron or larger suspended solids or aeration and suspended solids and aeration content which is smaller than 30 microns.

CASE 1:

Liquid that contains 25 to 10,000 PPM [1%] of 30 micron or larger suspended solids or aeration.

Select a transducer mounting location with adequate straight runs of pipe, both upstream and downstream, to achieve stable readings. Examples of minimum upstream and downstream requirements are included in **Table 1**.

Mount the transducers 180° apart and facing each other on the pipe. If the pipe is horizontal, the preferred mounting orientation is 3 and 9 o'clock, with 12 o'clock being the top of the pipe. Orientation on vertical pipes does not matter. See **Figure 4**.

PART 2 - TRANSDUCER INSTALLATION

Table 1¹

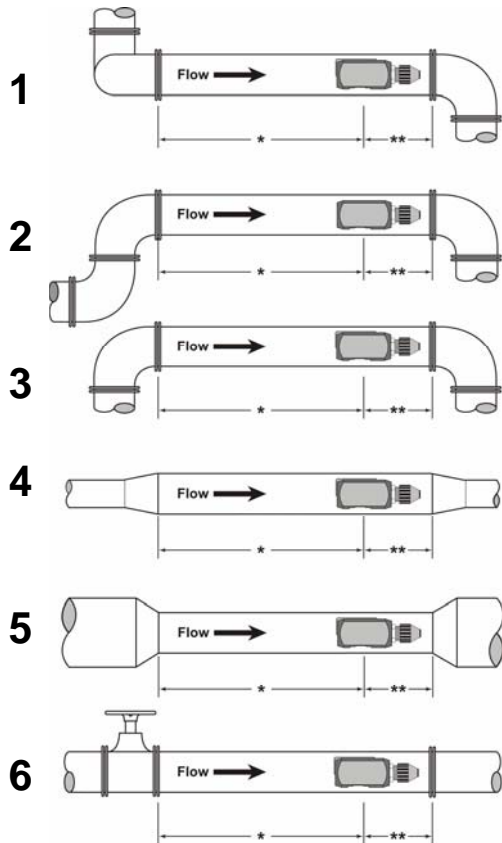

Example	Upstream Pipe Diameters	Downstream Pipe Diameters
	*	**
1	24	4
2	14	3
3	9	3
4	8	3
5	8	3
6	24	4

¹ The D901/M system will provide repeatable measurements on piping systems that do not meet these requirements, but the accuracy may be influenced to various degrees.

CASE 2:

Liquid that contains greater than 10,000 PPM [1%] of 30 micron or greater suspended solids or aeration.

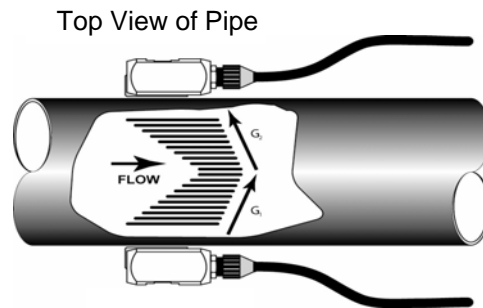

Figure 4

PART 2 - TRANSDUCER INSTALLATION

The mounting location and straight pipe requirements for CASE 2 liquid characteristics are the same as those describe in CASE 1. The difference will be in the location of the transducers on the pipe. As the discontinuities (suspended solids or aeration) reach a level of approximately 1% or 10,000 PPM, sound can no longer be reliably transmitted through the liquid as it has a tendency to scatter and absorb into the high concentration of

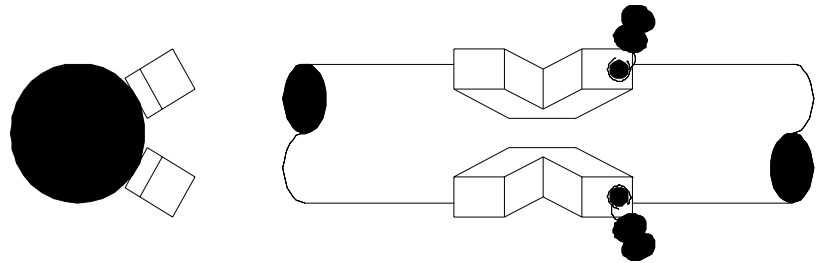

Figure 5

discontinuity. To compensate for this, the D901/M transducers can be located on the same region of the pipe. In a horizontal pipe, mount the transducers at 2 o'clock and 4 o'clock positions. (Assuming 12 o'clock as the top of the pipe.) See **Figure 5**.

CASE 3:

Liquid that contains fewer than 25 PPM of 30 micron or larger suspended solids or aeration. Or, liquid that contains solids or aeration which is smaller than 30 microns.

The transducers will be mounted 1 to 3 pipe diameters downstream from a 90° elbow. The orientation of the transducers on the pipe will be 180° apart and facing each other and 90° out of the plane of the elbow. See **Figure 6**.

PART 2 - TRANSDUCER INSTALLATION

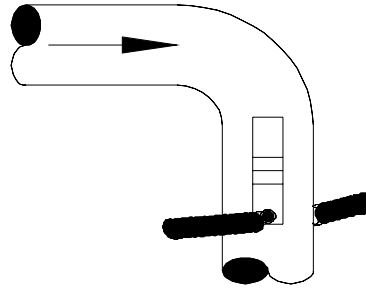

Figure 6

STEP B - PIPE SURFACE PREPARATION

Before the transducer heads are bonded to the pipe surface, an area slightly larger than the flat surface of the transducer must be cleaned to bare metal on the pipe. (Plastic pipes do not require preparation beyond removal of paint.) Remove all scale, rust and paint. Thoroughly dry and degrease the mounting surfaces.

NOTE: Small pits in the piping surface typically do not significantly impact ultrasonic transmission or signal reception.

STEP C - TRANSDUCER MOUNTING

After selecting the applicable mounting location and preparing the piping surface as detailed in A and B, the transducer can be mounted to the pipe.

To assure an acoustically conductive path between the transducer face and the prepared piping surface, a coupling compound is employed. Enclosed with the D901/M system is tube of Dow Corning RTV-732. This couplant is satisfactory for permanently mounting the transducers to the pipe. If the installation is temporary (less than a few days), Dynasonics recommends utilizing a silicone-based grease such as Dow Corning 111. The grease chosen must be rated to not flow at the temperature of the pipe.

PART 2 - TRANSDUCER INSTALLATION

PROCEDURE:

1. Select the proper number of transducer straps to allow a complete strap to go around the circumference of the pipe. See **Table 2** - The straps can be connected together to make a continuous length.

Table 2

Pipe Sizes		Straps Required
1" to 9"	25 to 225 mm	1
10" to 19"	250 to 480 mm	2
20" to 29"	500 to 740 mm	3
30" to 39"	760 to 1000 mm	4

2. Wrap the strap around the pipe in the area where the transducers are to be mounted. Leave the strap loose enough to allow the transducers to be placed underneath. If multiple straps are being used, it can be beneficial to wrap electrical tape around all but one strap connection to secure the strap worm screws in place.
3. Spread an even layer of coupling compound, approximately 1/8 inch [3mm] thick, to the prepared transducer mounting areas of the pipe. Utilize Dow 732 for permanent mounting or Dow 111 for temporary mounting,
4. Spread an even layer of coupling compound, approximately 1/8 inch [3mm] thick, to the flat face of the two transducers.
5. Place each transducer under the strap with the flat face positioned towards the pipe. The notch on the back of the transducer will provide a mounting surface for the strap. The transducer cables must be facing in

PART 2 - TRANSDUCER INSTALLATION

the same direction for proper operation. See **Figure 7**.
NOTE: Large pipes may require two people for this procedure.

6. Tighten the strap tight enough to hold the transducers in place, but not so tight that all of the couplant squeezes out of the gap between the transducer face and pipe. Ensure that the transducers are squarely aligned on the pipe.

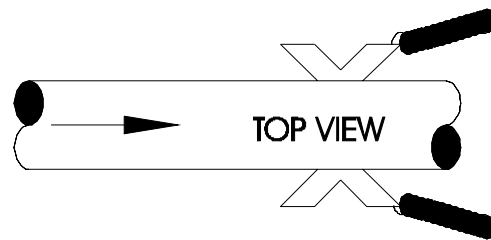

Figure 7

7. Route the transducer cable back to the transmitter mounting area avoiding high voltage cable trays and conduits. Do not attempt to add additional cable to the factory supplied transducer cable. The D901/M processes very small signals, so the cable shield must be continuous. Excess cable may be coiled to take up extra length.
8. If the transducers are to be permanently mounted using Dow 732, the RTV must be completely cured before proceeding to Instrument Start up. Ensure that no relative motion between the transducer and pipe occurs during the 24 hour curing process. If Dow 111 grease was used for temporary operation of the D901/M system, proceed with the Instrument Start-up procedures.

Transducer Installation is complete

PART 2 - TRANSMITTER INSTALLATION

Transmitter Installation

The enclosure should be mounted in an area that is convenient for servicing, calibration or for observation of the LCD readout.

1. Locate the transmitter within the length of transducer cable that was supplied with the D901/M system. If this is not possible, do not attempt to add additional cable to the transducer. Contact the Dynasonics factory to coordinate an exchange for the proper cable length. Transducer cables that are up to 300 feet [90 meters] are available.
2. Mount the D901/M transmitter in a location that is:

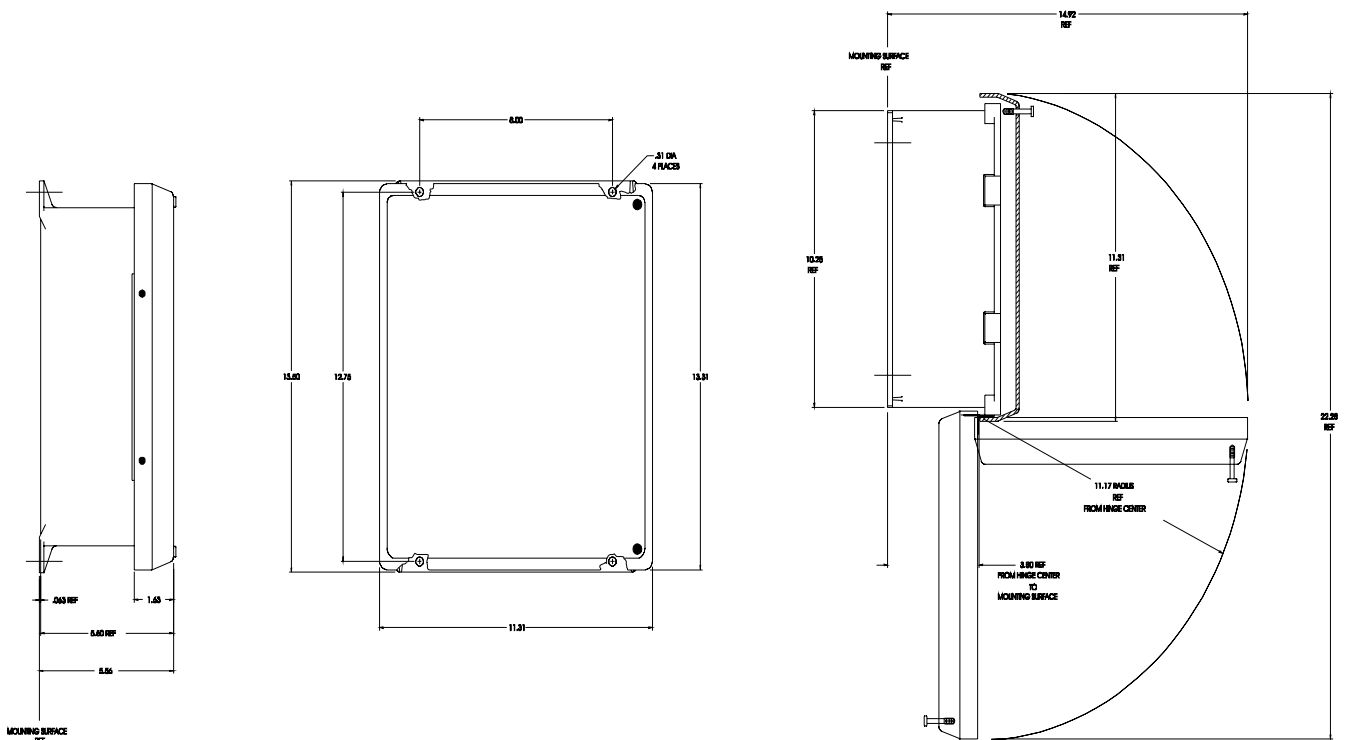

Figure 8

PART 2 - TRANSMITTER INSTALLATION

- ◆ Where little vibration exist.
 - ◆ Protected from falling corrosive fluids.
 - ◆ Within ambient temperature limits - 22 to 160°F [30 to 70°C]
 - ◆ Out of direct sunlight. A sun and weather shield is available from Dynasonics. P.N. D003-899-001. Direct sunlight may increase temperatures within the transmitter to above maximum limit.
3. Mounting: Refer to **Figure 8** for enclosure and mounting dimension details. Ensure that enough room is available to allow for door swing, maintenance and conduit entrances. Secure the enclosure to a flat surface with four appropriate fasteners.
 4. Conduit holes. Conduit hubs should be used where cables enter the enclosure. Holes not used for cable entry should be sealed with plugs.

NOTE: Use NEMA 4 [IP65] rated fittings plugs to maintain the water tight integrity of the enclosure. Generally, the left conduit hole (viewed from front) is used for line power; the right conduit hole for transducer connections.

5. If additional holes are required, (analog outputs, etc.) drill the appropriate size hole in the enclosure's bottom. Use extreme care not to run the drill bit into the wiring or circuits cards.

To access terminal strips for electronic connectors, loosen the two screws in the enclosure door and open the door. Loosen the two thumb-screws on the inner display door and open the door.

1. Guide the transducer terminations through the transmitter conduit hole located on the right side of the

ELECTRICAL CONNECTIONS

PART 2 - ELECTRICAL INSTALLATION

Transducer Connections

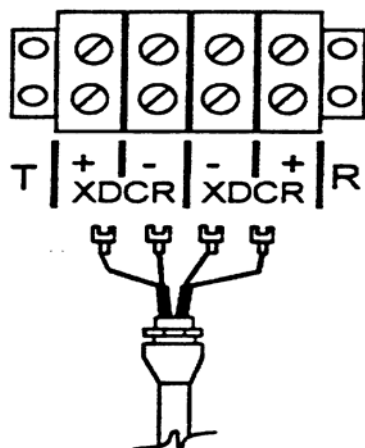

Figure 9

4-20 mA Output

Pulse Output

enclosure. Secure the transducer cable with the supplied conduit nut.

2. The terminals on the transducer cable are coded with wire markings. Connect the appropriate wires to the corresponding screw terminals in the transmitter. See **Figure 9**.

NOTE: The transducer cable carries low level signals. Do not attempt to add additional cable to the factory supplied transducer cable. If additional cable is required, contact the Dynasonics factory to arrange for an exchange transducer with the appropriate length of cable. Cables to 300 feet [90 meters] are available.

The 4-20mA output is proportional to the flow rate measuring scale and can drive a load of up to 600 ohms. The output is isolated from earth ground and circuit low. Connect the load to the **4-20 mA** screw terminals on the transmitter terminal block, matching polarity as indicated.

NOTE: An additional hole in the transmitter enclosure is required for outputs. Drill the hole in the the enclosure bottom taking care not to drive the drill bit into wiring or the circuit boards with the transmitter.

The pulse output is proportional to the flow rate measuring scale. This output may be used one of two ways:

- ◆ To drive a 12V logic device.
- ◆ To drive a low impedance, 12V device. Minimum resistance 50 ohms.

The pulse output is adjustable from a range of 0 - 600 Hz to 0 - 10kHz via control R29 [CTR] located on the left side of the signal processing PCB in the back of the enclosure. The pulse width is fixed at 50 μ seconds. CTR " - " represents circuit low. CTR " + " represents 12 Vdc pulse output.

PART 2 - ELECTRICAL INSTALLATION

Optional 0 - 1 mA Output

If the 0-1mA output has been installed on the D901/M, the connections are available on the screw terminal block in the transmitter. Connect a load of not more than 4 K ohms to the terminals. Adjust control R20 [1 mA] to fine tune the output to match the load impedance.

Line Power

Connect line power to the screw terminals marked AC, AC and GND in the transmitter. See **Figure 10**. Utilize the conduit hole on the left side of the enclosure for this purpose. Use wiring practices that conform to local codes (National Electric Code Hand book in the USA). Use only the standard three wire connection. The ground terminal grounds the instrument, which is mandatory for safe operation.

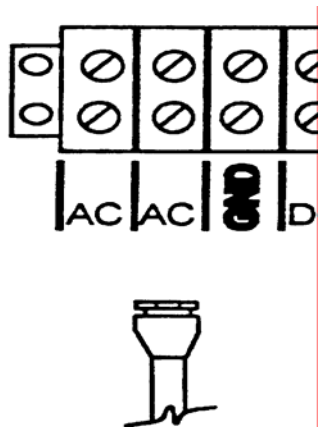

Figure 10

CAUTION: Any other wiring method may be unsafe or cause improper operation of the instrument.

It is recommended not to run line power with other signal wires within the same wiring tray or conduit.

NOTE: This instrument requires clean electrical line power. Do not operate this unit on circuits with noisy components (i.e. Fluorescent lights, relays, compressors, variable frequency drives, etc.).

If this option is installed, the D901/M can be operated from a 12 Vdc source, as long as it is capable of supplying 1 Ampere. Observe proper polarity.

Optional 12 Vdc power

PART 3 - STARTUP AND CONFIGURATION

Before Starting the Instrument

Instrument Startup

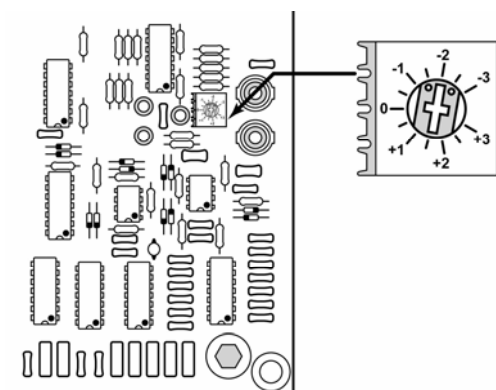

Sensitivity Adjustment Control

Note: The D901/M flow meter system requires a full pipe of liquid before a successful startup can be completed. Do not attempt to make adjustments or change configurations until a full pipe is verified.

Note: If Dow 732 RTV was utilized to couple the transducers to the pipe, the adhesive must fully cure before power is applied to the instrument. Dow 732 requires 24 hours to cure satisfactorily. If Dow 111 silicone grease was utilized as a couplant, the curing time is not required.

Procedure:

1. Verify that all wiring is properly connected and routed.
2. Set the SENSITIVITY Control to -2. This control is located on the inner door.
3. Apply power. The POWER indicator will illuminate.
4. Adjust the SENSITIVITY control so that the right-most LED on the SIGNAL STRENGTH bar meter just illuminates.

Note: It is undesirable to adjust the SENSITIVITY control to a position higher than necessary, as ambient noise can also be amplified. This noise can cause false readings to occur.

5. If the pipe is full of a flowing liquid, the READ indicator will illuminate and the display will begin reading fluid velocity as FPS (Feet per Second) or MPS (Meters per Second). It is normal to have low SIGNAL STRENGTH and FAULT indication at ZERO flow.
6. If a SIGNAL STRENGTH reading in the green portion of the bar meter could not be obtained, refer to the troubleshooting section of this manual.

After a successful flow meter installation and startup

PART 3 - STARTUP AND CONFIGURATION

Keypad Configurations

(covered in the previous sections of this manual) the D901/M can be keypad configured to provide select engineering unit readings of flow and a scaled 4-20mA output. Configuration inputs are made via the keypad and are stored by the microprocessor. The entries are retained by the flow meter's backup battery in the event of power failure. If fluid velocity readings, FPS or MPS, are the only required measurement keypad configuration is not required.

Modes of Operation

The RUN/ENT key toggles the flow meter between the two modes of operation.

RUN Mode: This is the primary operating mode of the flow meter. The meter is in RUN mode when the readout is displaying flow as velocity (FPS, MPS) OR volume (GPM, LPM, LPS). In RUN mode the outputs are active and transmitting signals proportional to flow rate.

ENTRY Mode: This mode is used to view or change the configuration of the flow meter. When the D901/M ships from the Dynasonics factory, it contains the following Default configuration:

Each of these parameters may be viewed and/or modified

Default Configuration

PARAMETER	US	METRIC
ID	1 Inch	25 mm
UNITS	1 [FPS]	1 [MPS]
DAMP	1 Sec	1 Sec
Volume/PLS	ϕ	ϕ
FULL SCALE	20 FPS	6.08 MPS
CAL	100%	100%

in the ENTRY Mode. Changes are processed when the RUN/ENT is pressed and the meter returns to RUN MODE. In ENTRY Mode flow totalization is suspended and process outputs are frozen at the last value recorded.

PART 3 - STARTUP AND CONFIGURATION

Pipe I.D. Input

The ID key allows the entry of a pipe's Internal Diameter. The D901/M utilizes the I.D. constant to process volumetric flow rates such as GPM (Gallons per Minute) or LPM (Liters per Minute). The entry is made as either inches or mm, dependent on whether the unit is configured as U.S. units or Metric units.

Press the I.D. key from the ENTRY MODE. The display will show

INSIDE DIAMETER

This is the present I.D. constant. Enter a new I.D. based on information obtained from the pipe manufacturer, a physical measurement or a pipe chart. Some common pipe sizes and dimensions are located on a series of charts located in the Appendix of this manual. The acceptable input range for the I.D. constant is shown in Table 3.

Table 3

I.D.	US	METRIC
Max	120 Inches	3050 mm
Min *	0.25 Inches	6 mm

* Pipe sizes less than 1 inch [25 mm] require a Small Pipe Transducer.

Note: If a decimal value of less than 1 is to be entered, enter 0 . X X . The zero must precede the decimal value.

Note: If an entered value is out of the acceptable range of the instrument, an UNDER! or OVER! indication will be displayed. The meter will not allow any other entries to be made until a legitimate value is entered.

PART 3 - STARTUP AND CONFIGURATION

Full Scale Input

The FULL SCALE key allows the entry of the highest anticipated fluid velocity. The entry is made as either FPS (Feet per Second) or MPS (Meters per Second), dependent on whether the unit is configured as US units or Metric units. The FULL SCALE input is used by the D901/M microprocessor to scale the 4-20mA output and adjust the resolution of the flow rate display.

Acceptable input range for the FULL SCALE constant is shown in Table 4.

Table 4

I.D.	US	METRIC
Max	40 FPS	8 MPS
Min *	n/a	n/a

* Note: FULL SCALE values below 1.5 FPS [0.5 MPS] are not recommended.

Note: If a decimal value is to be entered, enter 0 . X X . The zero must precede the decimal value and no more than two numbers should be entered after the decimal value.

Important!

Note: If an entered value is out of the acceptable range of the instrument, a RANGE! indication will be displayed. The meter will not allow any additional entries to be made until a legitimate value is entered.

Volume to Velocity Conversion

Two useful equations which relate volumetric flow in round pipes to flow velocity are as follows:

$$\text{FPS} = \frac{\text{U.S. GPM} \times 0.409}{\text{ID}^2 \text{ (inches)}}$$

$$\text{MPS} = \frac{\text{LPM} \times 21.23}{\text{ID}^2 \text{ (mm)}}$$

PART 3 - STARTUP AND CONFIGURATION

Totalizer Exponent Input

The VOL. PULSE key allows the entry of a totalizer exponent. This feature is useful for accommodating a large accumulated flow. The exponent is a " X 10 " multiplier, which can be from 0 (no multiplier) to 2 (X 100). For example, to totalize in GAL X 100, a VOL. PULSE value of 2 would be used (10^2 or 100).

Acceptable input range for the VOL. PULSE constant is shown in **Table 5**.

Table 5

I.D.	US	METRIC
Max	2	2
Min *	0	0

* Note: If an entry greater than 2 is attempted, the meter will display OVER!. If a non- whole number value is attempted, the meter will display RANGE!. A legitimate value will need to be entered.

After a VOL. PULSE value is entered, the display will reflect the unit as $0=10^0=X1$, $10^1=X10$ and $2=10^2=X100$.

Table 6 illustrates various codes and their display results.

Table 6

VOL. PULSE CODE	ENG. NOTATION	DISPLAY MAXIMUM
0	10E0	999,999
1	10E1	999,999
2	10E2	999,999

PART 3 - STARTUP AND CONFIGURATION

Important Note for MGD Configurations

When utilizing the MGD engineering UNITS, the totalizer defaults to a VOL. PULSE multiplier of 10E3. This is not reflected on the display. Example: In MGD mode, a VOL. PULSE entry of 3 will result in an effective accumulation of E106 gallons (millions of gallons).

Engineering Units Input

The UNITS key allows the selection of measuring units. **Table 7** shows applicable codes for the engineering units available.

Table 7

UNITS CODE	U.S.	METRIC
1	FPS	MPS
2	GPM	LPM
3	MGD	LPS

Attempting to enter values other than 1, 2 or 3 will result in an UNDER! or OVER! to be displayed. Non-whole number values will result in a RANGE! display. A legitimate value must be entered.

Altering the CALibration of the D901/M

A few factors can influence the readings of the D901/M flow meter. The CAL entry allows the user to compensate for flow discrepancies without affecting the factory calibration. Examples of situations that can cause reading discrepancies are:

- Operation on liquids with sonic velocity carrying properties that are different than water.
- Transducers mounted in non-recommended locations.
- Operation on fluids with a large amount of suspended solids.

PART 3 - STARTUP AND CONFIGURATION

By applying a CAL value other than 100%, the factory calibrated readings will be altered by the percentage entered. This CAL value will not be reflected in the 4-20mA or pulse outputs.

For example, if a reading of 175 GPM is displayed and the known flow rate is 160 GPM, a CAL value of

$$\frac{160 \text{ GPM}}{175 \text{ GPM}} \times 100 = 91.4\%$$

The D901/M will not allow decimal values to be entered as a CAL constant, so round to the nearest whole number. In this case 91%.

Acceptable input ranges for the CAL constant are shown in **Table 8**.

Table 8

I.D.	US	METRIC
Max	200%	200%
Min	3%	3%

Values outside of this range will result in an OVER! or UNDER! Display. Non-whole number entries will result in a RANGE! Display. Enter an appropriate value.

PART 3 - STARTUP AND CONFIGURATION

Display Damping

The DAMP key allows the selection of time duration between display updates. The value selected and entered will result in display updates of

$$n \times 2 = \text{seconds between updates}$$

Acceptable input ranges for the DAMP constant are shown in **Table 9**.

Table 9

I.D.	US	METRIC
Max	5	5
Min	0.5	0.5

Values outside of this range will result in an OVER! or UNDER! display. Entry of an appropriate value is required.

System Damping

Note: The D901/M circuit is calibrated at the factory to provide stable flow readings and outputs under normal flow conditions and liquid turbulence. In conditions where stability of readings and/or outputs are unsatisfactory, the response of the instrument can be changed by adjusting R17 (DAMP) control located left center on the main circuit card. Open the inner door of the flow meter and adjust with a small screwdriver.

The TEST Diagnostic Key

The TEST key is used for diagnostic purposes. It displays the operand presently available at the analog to digital converter. This value will always be in the range of 0 to 255.

PART 3 - STARTUP AND CONFIGURATION

System and Totalizer RESET

The RESET key is used for generating a system reset or to reset the accumulated (totalized) flow. Press the RESET button from the ENTER Mode. A choice is then made to :

RESET

Reset the system

VOL. MULT

Press VOL PULSE to re-set the totalizer to zero.

If the RESET key is pressed again, all configuration constants will return to default values.

If the VOL. PULSE key is pressed, the accumulated flow will be erased and the display will return to zero.

Reset the Flow Totalizer

In RUN Mode, pressing the decimal point once will suspend totalizer accumulation. Pressing the decimal point again will clear the total. Pressing it a third time will restart the accumulation from zero.

PART 4 - TROUBLE SHOOTING

CONDITION	POSSIBLE CAUSE
Unit does not turn “ON” when power is applied	<ul style="list-style-type: none"> • Check AC connections. • Test the fuse • Ensure the terminal block located in the upper left corner of the main PCB is secure • Verify that ribbon cables between PCBs are connected.
OVERRANGE light is ON	<ul style="list-style-type: none"> • Increase the value of the FULL SCALE constant. • Verify that fluid velocity is not greater than 20 FPS [6.08 MPS]
FAULT light is ON; low SIGNAL STRENGTH indication	<ul style="list-style-type: none"> • Ensure that the transducers are properly mounted to the pipe. • Verify that transducer connections are correct • Ensure that the pipe is full of moving liquid. • Increase SENSITIVITY so that right-most SIGNAL STRENGTH light just comes ON. • On cleaner liquids, move the transducers closer to a 90° pipe elbow. • On dirtier liquids, mount the transducers as described in CASE 3 of Part 2 of this manual. • If the pipe has a polyethylene liner, move the transducers to another area. The liner may contain an air void at this location. <p>(continued)</p>

PART 4 - TROUBLE SHOOTING

FAULT light is ON; low SIGNAL STRENGTH indication (continued)	<ul style="list-style-type: none">• If GND connection and pipe are at different potentials, ground D901/M to pipe potential.• If Variable Frequency Drives are being utilized, verify that the D901/M obtains a READ light when the pump turn OFF. If it does, contact the Dynasonics factory.
Stability of flow readings are unsatisfactory	<ul style="list-style-type: none">• Increase the DAMP constant from keypad.• Increase the system time constant by turning R17 (DAMP) clockwise till readings are satisfactory.• Move transducers to a location further from piping tees, elbows, valves, filters, etc.
Erroneous Reading	<ul style="list-style-type: none">• Transducers mounted incorrectly.• Another local ultrasonic instrument is operating at about the same frequency [consult the Dynasonics factory].• Presence of large amounts of suspended solids or aeration. Use CAL constant to compensate.• Sources of radiated interference are present. Apply appropriate shielding.• An electrically noisy power supply is powering the D901/M. Power the meter with a circuit that does not power motors, ballasts or switching supplies.
Readings of flow at zero fluid velocity	<ul style="list-style-type: none">• Verify that residual leakage and flow is not present. [i.e. leaking check valves]• Verify that SENSITIVITY is not adjusted too high. With nominal flow running through the pipe, adjust SENSITIVITY control till the right-most bar meter light just comes ON.

PART 5 - APPENDICES

Appendices

Relay Alarm Module Addendum

Pipe Dimension Chart: Cast Iron

Pipe Dimension Chart: Steel, SS, PVC

Velocity to Volumetric Conversion Chart

Statement of Warranty

Customer Service

Addendum — Relay Alarm Module

General

This addendum supplies information not covered in the standard *Installation and Operation Manual* supplied with the Series D901/D90M Ultrasonic Flowmeter Product. The Series D901/D90M product enclosed in this carton was purchased with an external relay alarm module. The module is enclosed and will need to be mounted separately from the D901/D90M enclosure.

Supplemental Specifications - Alarm Module

Loop Load equivalent	200 Ohms
Alarm Trip Point	Activated by setting trip point proportional to full scale FPS (example: to trip alarm at 2 FPS when FULL SCALE on the D901 is set to 10 FPS. Set alarm to $2/10 = 20\%$.)
Contact Rating	SPDT, 3 AMPS @ 28Vdc or 117 VAC resistive.
Dead Band	DIP switch selectable, see chart below

Connections

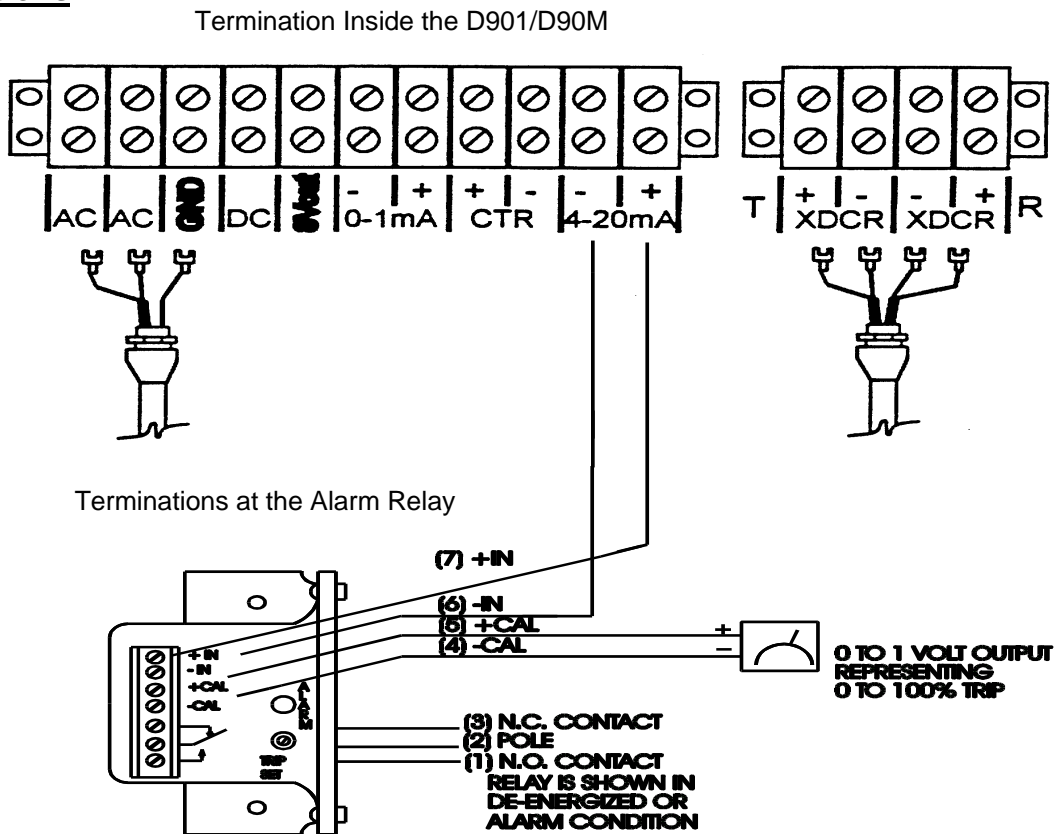

Addendum — Relay Alarm Module

Dead Band and Relay Operation Programming

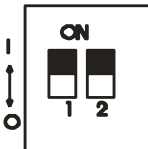
SWITCH		1	2	3	4	5	6	7	8
ALARM	HI	0	1	1	0				
	LO	1	0	0	1				
%DEAD BAND 	1					1	1	1	1
	2					0	0	0	1
	4					0	0	1	0
	6					0	1	0	0
	8					1	0	0	0
	16					0	0	0	0

DIP SWITCH CALIBRATION



Ductile Iron Pipe

Standard Classes

Pipe Size (inches)	Outside Diameter (inches)	Class 50		Class 51		Class 52		Class 53		Class 54		Class 55		Class 56		Cement Lining Std./Double Thickness
		ID	Wall	ID	Wall	ID	Wall	ID	Wall	ID	Wall	ID	Wall	ID	Wall	
3	3.96			3.46	0.25	3.40	0.28	3.34	0.31	3.28	0.34	3.22	0.37	3.14	0.41	.123/.250
4	4.80			4.28	0.26	4.22	0.29	4.16	0.32	4.10	0.35	4.04	0.38	3.93	0.44	
6	6.90	6.40	0.25	6.34	0.28	6.28	0.31	6.22	0.34	6.16	0.37	6.10	0.40	6.04	0.43	
8	9.05	8.51	0.27	8.45	0.30	8.39	0.33	8.33	0.36	8.27	0.39	8.21	0.42	8.15	0.45	
10	11.10	10.32	0.39	10.46	0.32	10.40	0.35	10.34	0.38	10.28	0.41	10.22	0.44	10.16	0.47	
12	13.20	12.58	0.31	12.52	0.34	12.46	0.37	12.40	0.40	12.34	0.43	12.28	0.46	12.22	0.49	
14	15.30	14.64	0.33	14.58	0.36	14.52	0.39	14.46	0.42	14.40	0.45	14.34	0.48	14.28	0.51	.1875/.375
16	17.40	16.72	0.34	16.66	0.37	16.60	0.40	16.54	0.43	16.48	0.46	16.42	0.49	16.36	0.52	
18	19.50	18.80	0.35	18.74	0.38	18.68	0.41	18.62	0.44	18.56	0.47	18.50	0.50	18.44	0.53	
20	21.60	20.88	0.36	20.82	0.39	20.76	0.42	20.70	0.45	20.64	0.48	20.58	0.51	20.52	0.54	
24	25.80	25.04	0.38	24.98	0.41	24.92	0.44	24.86	0.47	24.80	0.50	24.74	0.53	24.68	0.56	
30	32.00	31.22	0.39	31.14	0.43	31.06	0.47	30.98	0.51	30.90	0.55	30.82	0.59	30.74	0.63	.250/.500
36	38.30	37.44	0.43	37.34	0.48	37.06	0.62	37.14	0.58	37.40	0.45	36.94	0.68	36.84	0.73	
42	44.50	43.56	0.47	43.44	0.53	43.32	0.59	43.20	0.65	43.08	0.71	42.96	0.77	42.84	0.83	
48	50.80	49.78	0.51	49.64	0.58	49.50	0.65	49.36	0.72	49.22	0.79	49.08	0.86	48.94	0.93	
54	57.10	55.96	0.57	55.80	0.65	55.64	0.73	55.48	0.81	55.32	0.89	55.16	0.97	55.00	1.05	



Cast Iron Pipe Standard Classes

Size (Inches)	CLASS A			CLASS B			CLASS C			CLASS D			CLASS E			CLASS F			CLASS G			CLASS H			
	O.D. Inch	I.D. Inch	Wall	O.D. Inch	I.D. Inch	Wall	O.D. Inch	I.D. Inch	Wall	O.D. Inch	I.D. Inch	Wall	O.D. Inch	I.D. Inch	Wall	O.D. Inch	I.D. Inch	Wall	O.D. Inch	I.D. Inch	Wall	O.D. Inch	I.D. Inch	Wall	
3	3.80	3.02	0.39	3.96	3.12	0.42	3.96	3.06	0.45	3.96	3.00	0.48													
4	4.80	3.96	0.42	5.00	4.10	0.45	5.00	4.04	0.48	5.00	3.96	0.52													
6	6.90	6.02	0.44	7.10	6.14	0.48	7.10	6.08	0.51	7.10	6.00	0.55	7.22	6.06	0.58	7.22	6.00	0.61	7.38	6.08	0.65	7.38	6.00	0.69	
8	9.05	8.13	0.46	9.05	8.03	0.51	9.30	8.18	0.56	9.30	8.10	0.60	9.42	8.10	0.66	9.42	8.10	0.66	9.60	8.10	0.75	9.60	8.00	0.8	
10	11.10	10.10	0.50	11.10	9.96	0.57	11.40	10.16	0.62	11.40	10.04	0.68	11.60	10.12	0.74	11.60	10.00	0.80	11.84	10.12	0.86	11.84	10.00	0.92	
12	13.20	12.12	0.54	13.20	11.96	0.62	13.50	12.14	0.68	13.50	12.00	0.75	13.78	12.14	0.82	13.78	12.00	0.89	14.08	12.14	0.97	14.08	12.00	1.04	
14	15.30	14.16	0.57	15.30	13.98	0.66	15.65	14.17	0.74	15.65	14.01	0.82	15.98	14.18	0.90	15.98	14.00	0.99	16.32	14.18	1.07	16.32	14.00	1.16	
16	17.40	16.20	0.60	17.40	16.00	0.70	17.80	16.20	0.80	17.80	16.02	0.89	18.16	16.20	0.98	18.16	16.00	1.08	18.54	16.18	1.18	18.54	16.00	1.27	
18	19.50	18.22	0.64	19.50	18.00	0.75	19.92	18.18	0.87	19.92	18.00	0.96	20.34	18.20	1.07	20.34	18.00	1.17	20.78	18.22	1.28	20.78	18.00	1.39	
20	21.60	20.26	0.67	21.60	20.00	0.80	22.06	20.22	0.92	22.06	20.00	1.03	22.54	20.24	1.15	22.54	20.00	1.27	23.02	20.24	1.39	23.02	20.00	1.51	
24	25.80	24.28	0.76	25.80	24.02	0.89	26.32	24.22	1.05	26.32	24.00	1.16	26.90	24.28	1.31	26.90	24.00	1.45	27.76	24.26	1.75	27.76	24.00	1.88	
30	31.74	29.98	0.88	32.00	29.94	1.03	32.40	30.00	1.20	32.74	30.00	1.37	33.10	30.00	1.55	33.46	30.00	1.73							
36	37.96	35.98	0.99	38.30	36.00	1.15	38.70	35.98	1.36	39.16	36.00	1.58	39.60	36.00	1.80	40.04	36.00	2.02							
42	44.20	42.00	1.10	44.50	41.94	1.28	45.10	42.02	1.54	45.58	42.02	1.78													
48	50.50	47.98	1.26	50.80	47.96	1.42	51.40	47.98	1.71	51.98	48.00	1.99													
54	56.66	53.96	1.35	57.10	54.00	1.55	57.80	54.00	1.90	58.40	53.94	2.23													
60	62.80	60.02	1.39	63.40	60.06	1.67	64.20	60.20	2.00	64.82	60.06	2.38													
72	75.34	72.10	1.62	76.00	72.10	1.95	76.88	72.10	2.39																
84	87.54	84.10	1.72	88.54	84.10	2.22																			



Steel, Stainless Steel, P.V.C.

Standard Schedules

Nominal Pipe Size Inches	OUTSIDE DIAMETER	SCH. 5		SCH. 10 (LTWALL)		SCH. 20		SCH. 30		STD.		SCH. 40		SCH. 60		X STG.		SCH. 80		SCH. 100		SCH. 120		SCH. 140		SCH. 180		
		ID	Wall	ID	Wall	ID	Wall	ID	Wall	ID	Wall	ID	Wall	ID	Wall	ID	Wall	ID	Wall	ID	Wall	ID	Wall	ID	Wall	ID	Wall	
1	1.315	1.185	0.065	1.097	0.109					1.049		1.049	0.133			0.957	0.179	0.957	0.179								0.815	0.250
1.25	1.660	1.530	0.065	1.442	0.109					1.380		1.380	0.140			1.278	0.191	1.278	0.191								1.160	0.250
1.5	1.900	1.770	0.065	1.682	0.109					1.610		1.610	0.145			1.500	0.200	1.500	0.200								1.338	0.281
2	2.375	2.245	0.065	2.157	0.109					2.067		2.067	0.154			1.939	0.218	1.939	0.218								1.687	0.344
2.5	2.875	2.709	0.083	2.635	0.120					2.469		2.469	0.203			2.323	0.276	2.323	0.276								2.125	0.375
3	3.500	3.334	0.083	3.260	0.120					3.068		3.068	0.216			2.900	0.300	2.900	0.300								2.624	0.438
3.5	4.000	3.834	0.083	3.760	0.120					3.548		3.548	0.226			3.364	0.318	3.364	0.318									
4	4.500	4.334	0.083	4.260	0.120					4.026	0.237	4.026	0.237			3.826	0.337	3.826	0.337				3.624	0.438	3.624	0.438	3.438	0.531
5	5.563	5.345	0.109	5.295	0.134					5.047	0.258	5.047	0.258			4.813	0.375	4.813	0.375				4.563	0.500	4.563	0.500	4.313	0.625
6	6.625	6.407	0.109	6.357	0.134					6.065	0.280	6.065	0.280			5.761	0.432	5.761	0.432				5.501	0.562	5.501	0.562	5.187	0.719
8	8.625	8.407	0.109	8.329	0.148	8.125	0.250	8.071	0.277	7.981	0.322	7.981	0.322	7.813	0.406	7.625	0.500	7.625	0.500	7.437	0.594	7.187	0.719	7.187	0.719	6.183	1.221	
10	10.750	10.482	0.134	10.42	0.165	10.25	0.250	10.13	0.310	10.02	0.365	10.020	0.365	9.750	0.500	9.750	0.500	9.562	0.594	9.312	0.719	9.062	0.844	9.062	0.844	8.500	1.125	
12	12.750	12.420	0.165	12.39	0.180	12.25	0.250	12.09	0.330	12.00	0.375	11.938	0.406	11.626	0.562	11.750	0.500	11.370	0.690	11.060	0.845	10.750	1.000	10.750	1.000	10.120	1.315	
14	14.000			13.50	0.250	13.37	0.315	13.25	0.375	13.25	0.375	13.124	0.438	12.814	0.593	13.000	0.500	12.500	0.750	12.310	0.845	11.810	1.095	11.810	1.095	11.180	1.410	
16	16.000			15.50	0.250	15.37	0.315	15.25	0.375	15.25	0.375	15.000	0.500	14.688	0.656	15.000	0.500	14.310	0.845	13.930	1.035	13.560	1.220	13.560	1.220	12.810	1.595	
18	18.000			17.50	0.250	17.37	0.315	17.12	0.440	17.25	0.375	16.876	0.562	16.564	0.718	17.000	0.500	16.120	0.940	15.680	1.160	15.250	1.375	15.250	1.375	14.430	1.785	
20	20.000			19.50	0.250	19.25	0.375	19.25	0.375	19.25	0.375	18.814	0.593	18.376	0.812	19.000	0.500	17.930	1.035	17.430	1.285	17.000	1.500	17.000	1.500	16.060	1.970	
24	24.000			23.50	0.250	23.25	0.375	23.25	0.375	23.25	0.375	22.626	0.687	22.126	0.937	23.000	0.500	21.560	1.220	20.930	1.535	20.930	1.535	20.930	1.535	19.310	2.345	
30	30.000			29.37	0.315	29.00	0.500	29.00	0.500	29.25	0.375	29.250	0.375			29.000	0.500											
36	36.000			35.37	0.315	35.00	0.500	35.00	0.500	35.25	0.375	35.250	0.375			35.000	0.500											
42	42.000									41.25	0.375	41.250	0.375			41.000	0.500											
48	48.000									47.25	0.375	47.250	0.375			47.000	0.500											



FPS TO GPM CROSS - REFERENCE (Schedule 40)

Nominal Pipe (Inches)	I.D. INCH	1	1.5	2	2.5	3	3.5	4	4.5	5	5.5	6	6.5	7	7.5	8	8.5	9
1	1.05	2.6989	4.0484	5.3978	6.7473	8.097	9.4462	10.796	12.145	13.490	14.844	16.190	17.540	18.890	20.240	21.590	22.941	24.290
1.25	1.38	4.6620	6.9929	9.3239	11.655	13.99	16.317	18.648	20.979	23.310	25.641	27.970	30.300	32.630	34.960	37.300	39.627	41.958
1.5	1.61	6.3454	9.5182	12.691	15.864	19.04	22.209	25.382	28.555	31.730	34.900	38.070	41.250	44.420	47.590	50.760	53.936	57.109
2	2.07	10.489	15.734	20.979	26.224	31.47	36.713	41.958	47.202	52.450	57.692	62.940	68.180	73.430	78.670	83.920	89.160	94.405
2.5	2.47	14.935	22.402	29.870	37.337	44.80	52.272	59.740	67.207	74.670	82.142	89.610	97.080	104.50	112.00	119.50	126.95	134.41
3	3.07	23.072	34.608	46.144	57.680	69.22	80.752	92.288	103.82	115.40	126.90	138.40	150.00	161.50	173.00	184.60	196.11	207.65
3.5	3.55	30.851	46.276	61.702	77.127	92.55	107.98	123.40	138.83	154.30	169.68	185.10	200.50	216.00	231.40	246.80	262.23	277.66
4	4.03	39.758	59.636	79.515	99.394	119.3	139.15	159.03	178.91	198.80	218.67	238.50	258.40	278.30	298.20	318.10	337.94	357.82
5	5.05	62.430	93.645	124.86	156.07	187.3	218.50	249.72	280.93	312.10	343.36	374.60	405.80	437.00	468.20	499.40	530.65	561.87
6	6.06	89.899	134.85	179.80	224.75	269.7	314.65	359.60	404.55	449.50	494.45	539.40	584.30	629.30	674.20	719.20	764.14	809.09
8	7.98	155.89	233.83	311.78	389.72	467.7	545.61	623.56	701.50	779.40	857.39	935.30	1013.0	1091.0	1169.0	1247.0	1325.1	1403.0
10	10.02	245.78	368.67	491.56	614.45	737.3	860.23	983.12	1106.0	1229.0	1351.8	1475.0	1598.0	1720.0	1843.0	1966.0	2089.1	2212.0
12	11.94	348.99	523.49	697.99	872.49	1047.0	1221.5	1396.0	1570.5	1745.0	1919.5	2094.0	2268.0	2443.0	2617.0	2792.0	2966.5	3141.0
14	13.13	422.03	633.04	844.05	1055.1	1266.0	1477.1	1688.1	1899.1	2110.0	2321.1	2532.0	2743.0	2954.0	3165.0	3376.0	3587.2	3798.2
16	15.00	550.80	826.20	1101.6	1377.0	1652.0	1927.8	2203.2	2478.6	2754.0	3029.4	3305.0	3580.0	3856.0	4131.0	4406.0	4681.8	4957.2

FPS TO GPM: $GPM = (PIPE\ ID)^2 \times VELOCITY\ IN\ FPS \times 2.45$

GPM TO FPS: $FPS = \frac{GPM}{(ID)^2 \times 2.45}$

FPS X .3048 = MPS

GPM X .0007 = GPD

GPM X 3.7878 = LPM



FPS TO GPM CROSS - REFERENCE (Schedule 40)

Nominal Pipe (Inches)	I.D. INCH	1	1.5	2	2.5	3	3.5	4	4.5	5	5.5	6	6.5	7	7.5	8	8.5	9
18	16.88	697.52	1046.3	1395.0	1743.8	2093.0	2441.3	2790.1	3138.8	3488.0	3836.3	4185.0	4534.0	4883.0	5231.0	5580.0	5928.9	6277.7
20	18.81	866.14	1299.0	1732.0	2165.3	2598.4	3031.5	3464.6	3897.6	4330.7	4763.8	5196.8	5629.9	6063.0	6496.0	6929.1	7362.2	7795.3
24	22.63	1253.7	1880.0	2507.0	3134.1	3761.0	4387.8	5014.6	5641.5	6268.3	6895.1	7522.0	8148.8	8775.6	9402.4	10029	10656	11283
26	25.25	1560.7	2341.0	3121.0	3901.9	4682.2	5462.6	6243.0	7023.4	7803.7	8584.1	9364.5	10145	10925	11706	12486	13266	14047
28	27.25	1817.8	2727.0	3636.0	4544.5	5453.4	6362.3	7271.2	8180.0	9088.9	9997.8	10907	11816	12725	13633	14542	15451	16360
30	29.25	2094.4	3142.0	4189.0	5236.0	6283.2	7330.4	8377.6	9424.9	10472	11519	12566	13614	14661	15708	16755	17803	18850
32	31.25	2390.6	3586.0	4781.0	5976.5	7171.9	8367.2	9562.5	10758	11953	13148	14344	15539	16734	17930	19125	20320	21516
34	33.25	2706.4	4060.0	5413.0	6766.0	8119.2	9472.4	10826	12179	13532	14885	16238	17592	18945	20298	21651	23004	24358
36	35.25	3041.8	4563.0	6084.0	7604.5	9125.4	10646	12167	13688	15209	16730	18251	19772	21292	22813	24334	25855	27376
42	41.25	4165.4	6248.0	8331.0	10414	12496	14579	16662	18744	20827	22910	24992	27075	29158	31241	33323	35406	37489
48	47.99	5637.8	8457.0	11276	14095	16913	19732	22551	25370	28189	31008	33827	36646	39465	42284	45103	47922	50740
54	53.98	7133.1	10700	14266	17833	21399	24966	28532	32099	35665	39232	42798	46365	49931	53498	57065	60631	64198
60	60.09	8839.2	13259	17678	22098	26518	30937	35357	39777	44196	48616	53035	57455	61875	66294	70714	75134	79553
72	72.10	12726	19089	25451	31814	38177	44540	50903	57266	63628	69991	76354	82717	89080	95443	101805	108168	114531
84	84.10	17314	25971	34628	43285	51943	60600	69257	77914	86571	95228	103885	112542	121199	129856	138514	147171	155828

FPS TO GPM: $GPM = (PIPE\ ID)^2 \times VELOCITY\ IN\ FPS \times 2.45$

GPM TO FPS: $FPS = \frac{GPM}{(ID)^2 \times 2.45}$

FPS X .3048 = MPS

GPM X .0007 = GPD

GPM X 3.7878 = LPM

Fluid Sound Speeds

Original Date: 10/19/99
 Revision: none
 Revision Date: none
 File: I:/dynasonics/dyna_code/tables/doppler ss conversions.xls
 120.0176921

Fluid	Specific Gravity 20 degrees C	Sound Speed		Doppler
		m/s	ft/s	Calibration Entry relative to 25C water
Acetate, Butyl (n)		1270	4163.9	85
Acetate, Ethyl	0.901	1085	3559.7	72
Acetate, Methyl	0.934	1211	3973.1	81
Acetate, Propyl		1280	4196.7	85
Acetone	0.79	1174	3851.7	78
Alcohol	0.79	1207	3960.0	81
Alcohol, Butyl (n)	0.83	1270	4163.9	85
Alcohol, Ethyl	0.83	1180	3868.9	79
Alcohol, Methyl	0.791	1120	3672.1	75
Alcohol, Propyl (l)		1170	3836.1	78
Alcohol, Propyl (n)	0.78	1222	4009.2	82
Ammonia (35)	0.77	1729	5672.6	115
Aniline (41)	1.02	1639	5377.3	109
Benzene (29,40,41)	0.88	1306	4284.8	87
Benzol, Ethyl	0.867	1338	4389.8	89
Bromine (21)	2.93	889	2916.7	59
n-Butane (2)	0.60	1085	3559.7	72
Butyrate, Ethyl		1170	3836.1	78
Carbon dioxide (26)	1.10	839	2752.6	56
Carbon tetrachloride	1.60	926	3038.1	62
Chloro-benzene	1.11	1273	4176.5	85
Chloroform (47)	1.49	979	3211.9	65
Diethyl ether	0.71	985	3231.6	66
Diethyl Ketone		1310	4295.1	87
Diethylene glycol	1.12	1586	5203.4	106
Ethanol	0.79	1207	3960.0	81
Ethyl alcohol	0.79	1207	3960.0	81
Ether	0.71	985	3231.6	66
Ethyl ether	0.71	985	3231.6	66
Ethylene glycol	1.11	1658	5439.6	111
Freon R12		774.2	2540	52
Gasoline	0.7	1250	4098.4	83
Glycerin	1.26	1904	6246.7	127
Glycol	1.11	1658	5439.6	111
Isobutanol	0.81	1212	3976.4	81
Iso-Butane		1219.8	4002	81
Isopentane (36)	0.62	980	3215.2	65
Isopropanol (46)	0.79	1170	3838.6	78
Isopropyl alcohol (46)	0.79	1170	3838.6	78
Kerosene	0.81	1324	4343.8	88
Linalool		1400	4590.2	93

Linseed Oil	.925-.939	1770	5803.3	118
Methanol (40,41)	0.79	1076	3530.2	72
Methyl alcohol (40,44)	0.79	1076	3530.2	72
Methylene chloride (3)	1.33	1070	3510.5	71
Methylethyl Ketone		1210	3967.2	81
Motor Oil (SAE 20/30)	.88-.935	1487	4875.4	99
Octane (23)	0.70	1172	3845.1	78
Oil, Castor	0.97	1477	4845.8	99
Oil, Diesel	0.80	1250	4101	83
Oil (Lubricating X200)		1530	5019.9	102
Oil (Olive)	0.91	1431	4694.9	96
Oil (Peanut)	0.94	1458	4783.5	97
Paraffin Oil		1420	4655.7	95
Pentane	0.626	1020	3346.5	68
Petroleum	0.876	1290	4229.5	86
1-Propanol (46)	0.78	1222	4009.2	82
Refrigerant 11 (3,4)	1.49	828.3	2717.5	55
Refrigerant 12 (3)	1.52	774.1	2539.7	52
Refrigerant 14 (14)	1.75	875.24	2871.5	58
Refrigerant 21 (3)	1.43	891	2923.2	59
Refrigerant 22 (3)	1.49	893.9	2932.7	60
Refrigerant 113 (3)	1.56	783.7	2571.2	52
Refrigerant 114 (3)	1.46	665.3	2182.7	44
Refrigerant 115 (3)		656.4	2153.5	44
Refrigerant C318 (3)	1.62	574	1883.2	38
Silicone (30 cp)	0.99	990	3248	66
Toluene (16,52)	0.87	1328	4357	89
Transformer Oil		1390	4557.4	93
Trichlorethylene		1050	3442.6	70
1,1,1-Trichloro-ethane	1.33	985	3231.6	66
Turpentine	0.88	1255	4117.5	84
Water, distilled (49,50)	0.996	1498	4914.7	100
Water 0 degrees C		1402	4596.7	94
Water 20 degrees C		1482	4859.0	99
Water 40 degrees C		1529	5013.1	102
Water 60 degrees C		1551	5085.2	103
Water 80 degrees C		1554	5095.1	104
Water 100 degrees C		1543	5059.0	103
Water 120 degrees C		1519	4980.3	101
Water 140 degrees C		1485	4868.9	99
Water 160 degrees C		1440	4721.3	96
Water 180 degrees C		1390	4557.4	93
Water 200 degrees C		1333	4370.5	89
Water, heavy	1	1400	4593	93
Water, sea	1.025	1531	5023	102
Wood Alcohol (40,41)	0.791	1076	3530.2	72
m-Xylene (46)	0.868	1343	4406.2	90
o-Xylene (29,46)	0.897	1331.5	4368.4	89
p-Xylene (46)		1334	4376.8	89



GENERAL TERMS AND CONDITIONS OF SALES

1. **PAYMENT** – Terms of payment are effective from the actual date of invoice. If, in the Seller's opinion, the financial condition of the Buyer at any time – or any other circumstances – do not justify the incurrence of production costs of shipment on the terms of payment specified, the Seller may require partial or full payment in advance. Payment terms are net 30 days unless otherwise stated on invoice.
2. **F.O.B.** – All shipments are from Racine, Wisconsin, USA, unless otherwise other stated, and title transfers to the buyer upon leaving factory.
3. **QUOTATION AND PRICES** – Quoted prices are firm for 30 days unless stated in the quotation and are subject to change without notice after expiration of this period.
4. **TAXES** – Any applicable sales, use, revenue, excise or other taxes not specifically stated in the quotation are to be remitted by the Buyer directly to the appropriate regulatory agency.
5. **WARRANTY** – Seller's standard published warranty in effect at the time of shipment shall apply. This warranty is exclusive and is in lieu of all other warranties, express, implied, or statutory, including the warranty of merchantability.
6. **DELIVERY** – The Seller shall not be liable for loss or damage of any kind resulting from delay or inability to deliver on account of flood, fire, labor trouble, riots, civil disturbances, accidents, acts or orders or regulations of civil or military authorities, shortages of material, or any other causes beyond Seller's control.
7. **PRODUCT CHANGES** – In keeping with our continuing policy of product improvement, we reserve the right to make changes in our products at any time, without incurring an obligation to change, replace or upgrade equipment previously shipped.
8. **CANCELLATIONS** – An order placed by Buyer and accepted by Seller may be cancelled only with the Seller's consent and upon terms that will indemnify the Seller against loss.
9. **RESTOCKING CHARGE** – On standard equipment, the charge is 25%, provided the equipment is returned within 30 days in acceptable condition with a RGA number. Restocking charges for special equipment may vary from standard equipment, and will be handled on a case-by-case basis. No returns will be taken after one year.



Limited Warranty and Disclaimer

Dynasonics, div. of Racine Federated Inc. warrants to the end purchaser, for a period of one year from the date of shipment from our factory, that all new transmitters and transducers manufactured by it are free from defects in materials and workmanship. This warranty does not cover products that have been damaged due to normal use, misapplication, abuse, lack of maintenance, or improper installation. Dynasonics' obligation under this warranty is limited to the repair or replacement of a defective product, at no charge to the end purchaser, if the product is inspected by Dynasonics and found to be defective. Repair or replacement is at Dynasonics' discretion. An authorization number must be obtained from Dynasonics before any product may be returned for warranty repair or replacement. The product must be thoroughly cleaned and any process chemicals removed before it will be accepted for return.

The purchaser must determine the applicability of the product for its desired use and assumes all risks in connection therewith. Dynasonics assumes no responsibility or liability for any omissions or errors in connection with the use of its products. Dynasonics will under no circumstances be liable for any incidental, consequential, contingent or special damages or loss to any person or property arising out of the failure of any product, component or accessory.

All expressed or implied warranties, including **the implied warranty of merchantability and the implied warranty of fitness for a particular purpose or application are expressly disclaimed** and shall not apply to any products sold or services rendered by Dynasonics.

The above warranty supersedes and is in lieu of all other warranties, either expressed or implied and all other obligations or liabilities. No agent or representative has any authority to alter the terms of this warranty in any way.

RETURN OF EQUIPMENT/SALES INFORMATION

CONTACTS AND PROCEDURES

Customer Service/Application Engineer:

If you have a question regarding order status, placing an order, reviewing applications for future purchases, or wish to purchase a new flowmeter, please contact our new National Sales and Marketing Headquarters:

DYNASONICS
Division of Racine Federated, Inc.
8635 Washington Avenue
Racine, WI 53406
PHONE: (800)535-3569 or
(262)639-6770
FAX: (262)639-2267

Service/Repair Department:

If you already purchased equipment and have an operation problem, require service, or need to schedule field service, please contact our Service Department:

DYNASONICS
Division of Racine Federated, Inc.
8635 Washington Avenue
Racine, WI 53406
PHONE: (800)535-3569 or
(262)639-6770
FAX: (262)639-2267

Return Goods Authorization:

When returning equipment, it is necessary for you to contact our Service Department at (800)535-3569 or (262)639-6770 to obtain an RGA number for the authority and proper tracking of your material and its prompt inspection and return. The RGA number should be noted on the outside of the box. All returns of equipment go to the following address:

DYNASONICS
Division of Racine Federated, Inc.
8635 Washington Avenue
Racine, WI 53406
Attn: RGA #



8635 WASHINGTON AVENUE
RACINE, WI 53406

TOLL-FREE IN NORTH AMERICA.:

TEL: (800) 535-3569 FAX: (800) 732-8354

TEL: (262) 639-6770 FAX: (262) 639-2267

URL: www.dynasonics.com